



NAME: \_\_\_\_\_

GRADE: \_\_\_\_\_

1

**HILLCREST HIGH SCHOOL**

**GRADE 9 TECHNOLOGY EXAM JUNE 2014**

**TIME: 2 HOURS**

**MARKS: 150**

**Instructions:**

Answer on this question paper. Answer all the questions. There are 14 questions.

**QUESTION 1: MATCHING COLUMNS - FORCES - (10)**

Choose a description from column B that matches an item in column A. Write only the letter in the blank column in the middle of the table.

COLUMN A	ANSWER	COLUMN B
1.1 Forces		A. A force that occurs when opposite forces tear an object in two.
1.2 Dynamic Forces		B. A force such as gravity, electricity and magnetism.
1.3 Static Forces		C. A force that occurs when equal and opposite forces make an object longer.
1.4 Contact Forces		D. Forces acting on an object when it is moving.
1.5 Non-contact forces		E. A force that occurs when equal and opposite forces squash an object.
1.6 Tension		F. A push or pull action on an object.
1.7 Compression		G. An object spanning a gap which is weak in tension and must be reinforced with steel.
1.8 Torsion		H. A force that directly touches an object.
1.9 Shearing		I. A turning force that makes an object twist.
1.10 Concrete beam		J. A force acting on an object when it is not moving.

**QUESTION 2: TRUE OR FALSE (10)**

State whether the following statements are true or false. Write the answer in column B.

COLUMN A	COLUMN B
2.1 Density - the amount of matter in grams that fills a particular volume.	
2.2 Mass – a measurement of the level of density of a material.	
2.3 Hardness – the ability of a material not to bend or lose shape under pressure.	
2.4 Stiffness – the ability of material to resist scratches wear and tear, or denting.	
2.5 Flexibility – the property of a material to bend and return to its original shape.	
2.6 Corrosion – a reaction between a metal and gases. The metal oxidizes.	
2.7 Durability - the ability of material not to be affected by events such as fire or earthquakes.	
2.8 Resistant - the ability of a material to stand up to wear and tear.	
2.9 Brittleness – material that breaks easily.	
2.10 Fatigue – failure of material caused by repeated stretching.	

**QUESTION 3 – MULTIPLE CHOICE (10) Circle the correct answer**

Read through each of the following statements. Circle the correct answer.

**3.1 Cross-bracing in construction is:**

- A Used to form triangular shapes.
- B Used to reinforce the structure with beams that cross over each other to form an X shape.
- C Used to make a structure more rigid.
- D All of the above

**3.2 The Eiffel Tower is made from pure iron. This gives it the property of:**

- A Corrosion resistance
- B Flexibility and strength
- C Brittleness
- D None of the above

**3.3 Toughness is the ability of a material to:**

- A Stretch
- B Shrink
- C Stand up to sudden blows or shocks
- D Resist water

**3.4 Stability is the ability of a material to:**

- A Stand up straight
- B Resist scratching
- C Resist rusting
- D Resist changes in its shape and size in wet or dry conditions over time

**3.5 Buildings with big windows should use:**

- A Reinforced glass
- B Tinted glass
- C Stained glass
- D Flexible glass

**3.6 Factors affecting the cost of materials are:**

- A Local availability
- B Durability
- C Resistance to fatigue
- D All of the above

**3.7 The suitability of construction material is determined by:**

- A Their properties
- B Safety
- C Cost effectiveness
- D All of the above

**3.8 Structures must be able to stand up to the elements such as:**

- A Water
- B Wind
- C Sunlight
- D All of the above

**3.9 To strengthen concrete use**

- A Wood
- B Straw
- C Steel bars
- D Stones

**3.10 Bricks are:**

- A Flexible
- B Scratch resistant
- C See through
- D Brittle

**QUESTION 4: SAFETY EQUIPMENT (5)**

Construction workers work with dangerous substances and in dangerous conditions. List 5 safety items they could use to protect themselves.

--

**QUESTION 5: MATCHING COLUMNS – HYDRAULICS, PNEUMATICS (10)**

Choose a description from column B that matches an item in column A. Write only the letter in the blank column in the middle of the table.

COLUMN A	ANSWER	COLUMN B
1.1 Cylinder		A. Is an example of a pneumatic machine
1.2 Master cylinder		B. A system that uses compressed fluid to do work
1.3 Slave cylinder		C. Are an example of a hydraulic system.
1.4 Piston		D. When something is squashed into a small space
1.5 Pneumatic system		E. A system that uses compressed air to do work
1.6 Potential energy		F. A tube that can fill up with liquid or air
1.7 Compressed		G. Energy that is released when stationary objects move
1.8 Hydraulic system		H. Input pressure is applied to this cylinder
1.9 Jackhammer		I. A disc joined to a rod that moves up and down a cylinder
1.10 Car brakes		J. Output pressure occurs at this cylinder

**QUESTION 11 (20)**

Look at the first angle orthographic drawing below. There is a front, a side and a top view.

- Copy this drawing and use a scale of 1:1
- Add dimensions and dimension lines to show height, width and length of the object. Dimension the circle as well.
- All hidden detail must be shown as well.

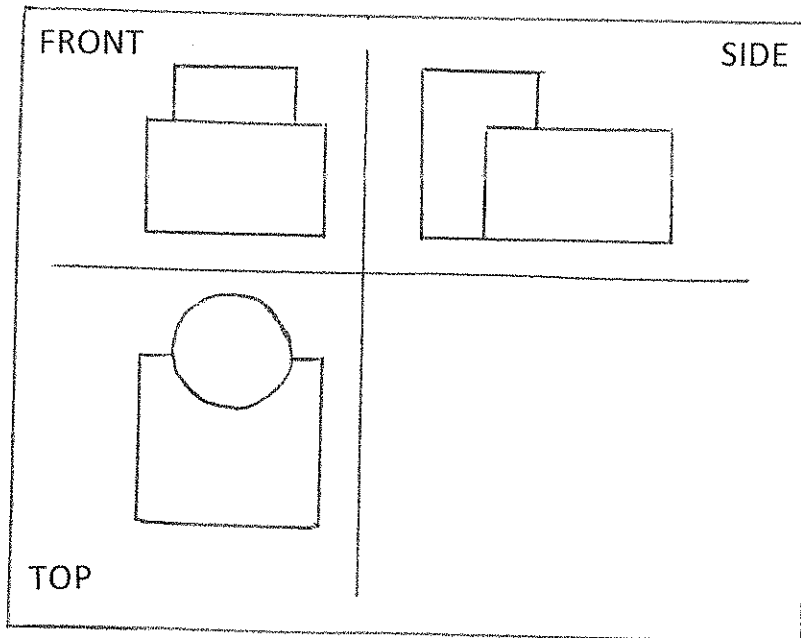

**QUESTION 12 (14)**

All the types of drawing lines have been used in the figure below of a pedestal bearing. Identify each type of line and state its use in the table below.

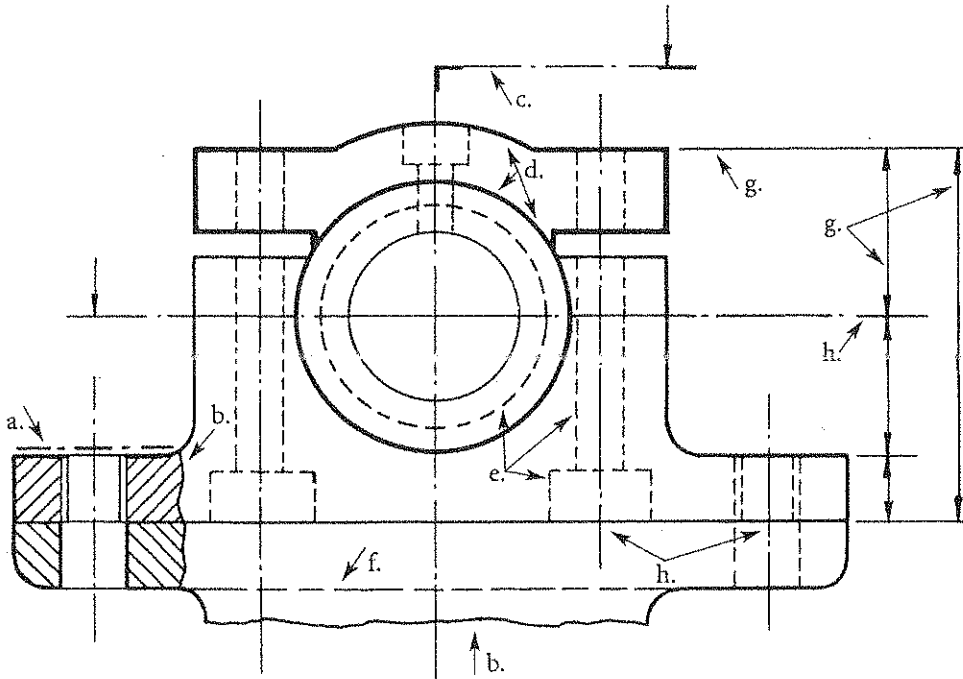

Type of line	Use of line
a.	
b.	
c.	
d.	
e.	
f.	
g.	
h.	

**QUESTION 13: DIMENSIONS AND SCALE (4)**

Look at the scale drawings below.

A – has been drawn to a scale of 1:2.

13.1 What is the scale for B? (1) \_\_\_\_\_

13.2 What is the scale for C? (1) \_\_\_\_\_

13.3 Fill in the measurements for B and C on the dimension lines below. (2)

A



B



C

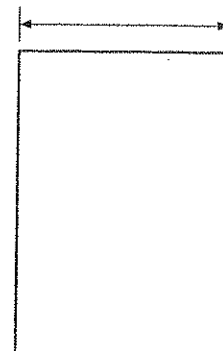

**QUESTION 14: ISOMETRIC TO ORTHOGRAPHIC (30)**

You have been given an isometric drawing. Do an orthographic drawing in the space provided below.

Show the hidden detail as well.

