



**GRADE 12**

**JUNE EXAM**

**MARKS: 120**

**TIME: 2 Hours**

---

**Instructions:**

1. Answer ALL the questions
2. Number and answer correctly according to the numbering system used in the question paper.
3. Present your answer according to the instructions of each question.
4. Do ALL drawings in pencil and label them in blue or black ink.
5. Write neatly and legibly.

## SECTION A

### QUESTION 1

1.1 Various options are provided as possible answers to the following questions. Choose the answer and write only the letter (**A to D**) next to the question numbers (1.1.1 to 1.1.9) in the ANSWER BOOK, e.g 1.1.10 D.

1.1.1 Which part of the male reproductive system secretes testosterone?

- A Cowper's glands
- B Prostate gland
- C Testis
- D Epididymis

1.1.2 Which ONE of the following represents the CORRECT sequence of development in humans?

- A Zygote → morula → blastocyst → foetus
- B Morula → blastocyst → zygote → foetus
- C Foetus → morula → blastocyst → zygote
- D Zygote → foetus → morula → blastocyst

1.1.3 A function of the medulla oblongata is to...

- A control higher thought processes.
- B regulate blood glucose levels.
- C regulate breathing.
- D inhibit voluntary movement.

1.1.4 A disorder of the brain that is characterised by memory loss and confusion is..

- A Alzheimer's disease.
- B haemophilia
- C multiple sclerosis.
- D Down syndrome.

1.1.5 The part of a sperm cell that contains enzymes to digest the membrane of the ovum is the...

- A tail.
- B mid-phase.

- C nucleus.
- D acrosome.

1.1.6 Depth perception refers to the ability to judge distance.

An investigation was carried out to determine the effect of using one eye only or both eyes on depth perception.

Participants were asked to thread a needle as a test of depth perception. The number of attempts needed to successfully thread the needle was counted when using one eye only and then when using both eyes.

The results of the investigation are provided in the table below.

EYES USED	NUMBER OF ATTEMPTS
One eye only	12
Both eyes	2

The results of this investigation show that...

- A binocular vision reduces depth perception.
- B using one eye only increases depth perception.
- C the number of eyes used has no effect on depth perception.
- D binocular vision increases depth perception.

**(2 X 6 = 12)**

1.2 Give the correct **biological term** for each of the following descriptions. Write only the term next to the question number (1.2.1 to 1.2.9) in the ANSWER BOOK.

1.2.1 A hormone that stimulates the maturation of sperm and puberty in males.

1.2.2 The tube in the male reproductive system that connects the epididymis with the urethra.

1.2.3 The hormone that stimulates the mammary glands to secrete milk.

1.2.4 The division of the cytoplasm through the constriction of the cell membrane at the end of cell division.

1.2.5 Neurons that carry impulses from receptors.

1.2.6 The series of changes that take place in the shape of the lens and the eyeball in response to the distance of an object from the eye.

**(2 X 6 = 12)**

- 1.3 Indicate whether each of the descriptions in COLUMN I applies to **A ONLY**, **B ONLY**, **BOTH A AND B** or **NONE** of the items in COLUMN II. Write **A only**, **B only**, **both A and B**, or **none** next to the question number (1.2.1 to 1.2.2) in the ANSWER BOOK.

COLUMN I	COLUMN II
1.3.1 The development in some birds where the hatchlings are able to feed on their own	A Precocial B Altricial
1.3.2 Holds together chromatids	A Chiasma B Centromere
1.3.3 A structure in the nervous system that detects a stimulus	A effector B receptor

- 1.4 The diagram below represents a possible 'path' followed by an impulse when a person touched a hot plate.

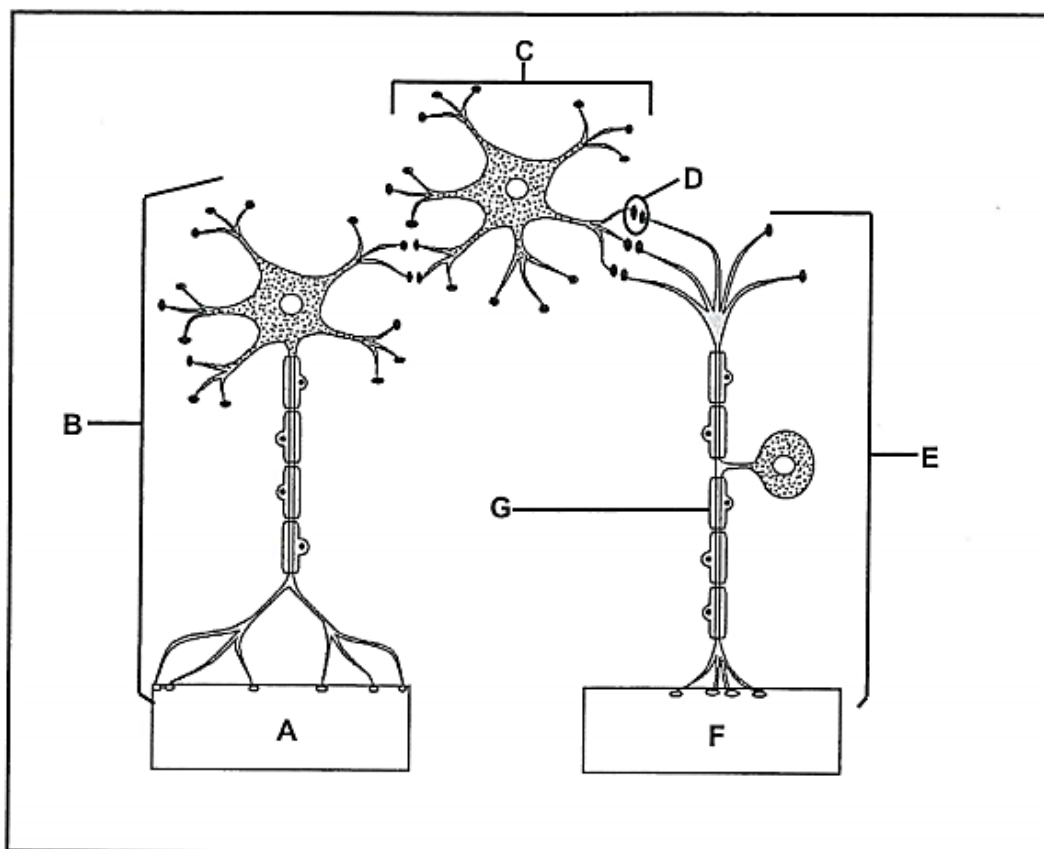

1.4.1 Name the 'path' represented in the diagram. (1)

1.4.2 Identify the type of neuron represented by:

(a) B (1)

(b) C (1)

(c) E (1)

1.4.3 Give the LETTER only of the part that represents the:

(a) Receptor (1)

(b) Effector (1)

1.4.4 Give the LETTER and NAME of the:

(a) Region where the impulse is transmitted chemically (2)

(b) Part that has an insulating function (2)

(10)

1.5 Study the diagram below of the sequence of events that takes place from the fertilisation of the ovum to the development of the embryo in a part of the human female reproductive system.

The arrows indicate the direction of development of one ovum after fertilisation.

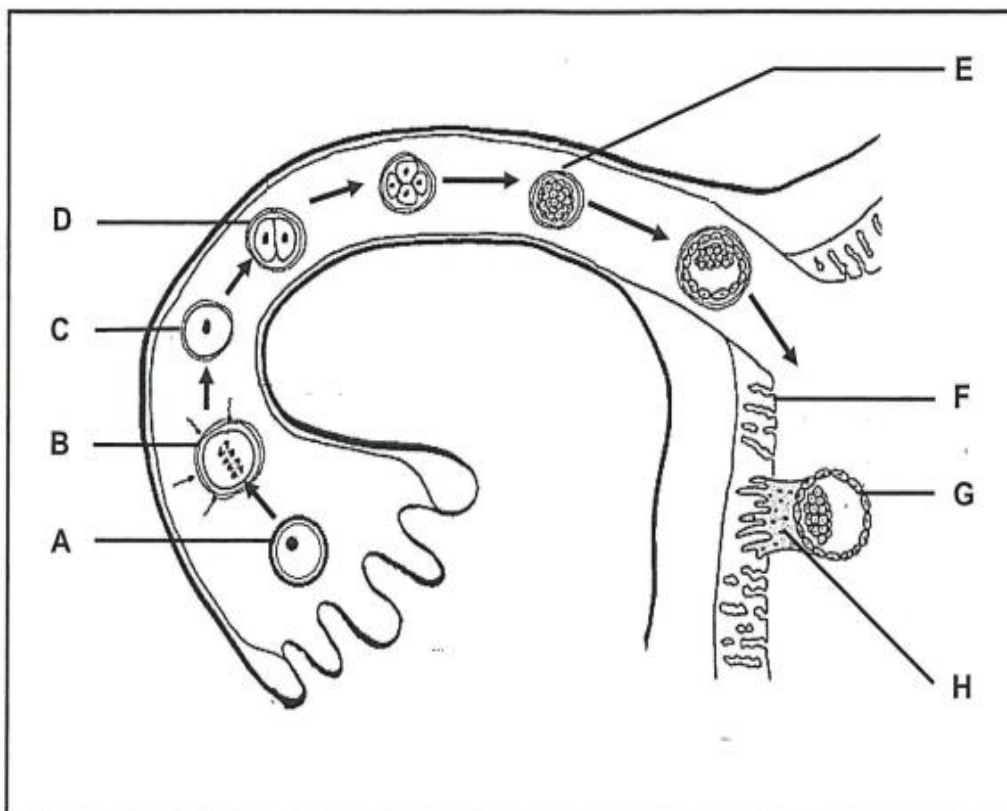

1.5.1 Identify:

- (a) Structure **C** (1)
- (b) The stage of embryo development at **E** (1)
- (c) The structure that develops from a combination of parts **F** and **H** (1)

1.5.2 Name the process that takes place:

- (a) At **B** (1)
- (b) When **G** attached to part **F** (1)

1.5.3 Give the chromosome number of:

- (a) The cells at **D** (1)
- (b) Cell **A** (1)

**(7)**

## SECTION B

### QUESTION 2

- 2.1 The graph below shows the concentration of progesterone in a woman's blood during the early stages of pregnancy.

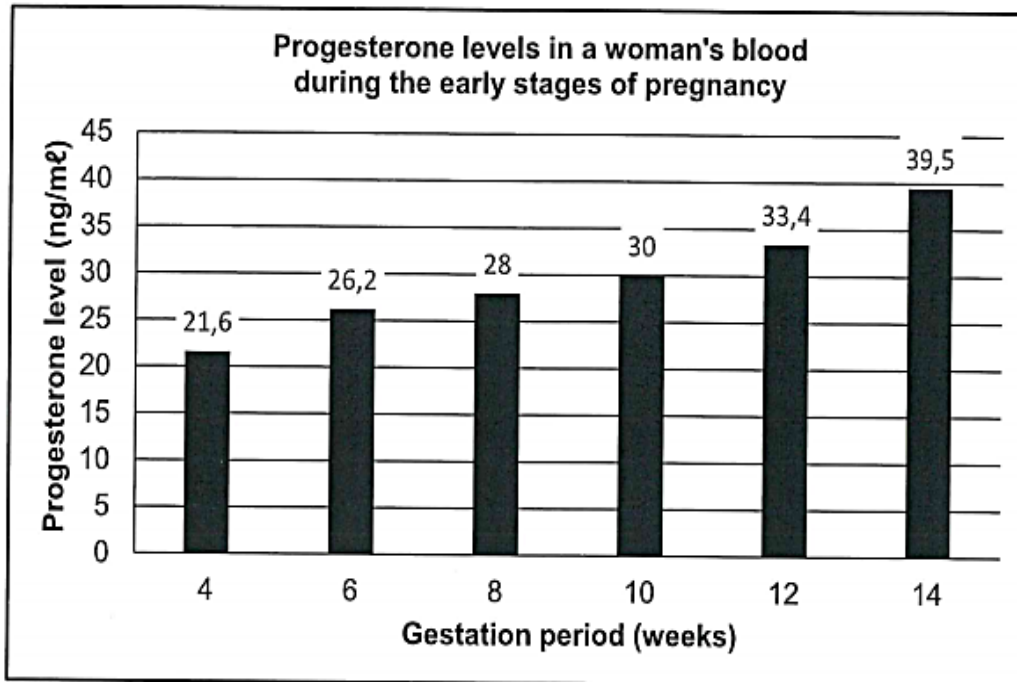

- 2.1.1 Name TWO structures responsible for producing progesterone during pregnancy. (2)
- 2.1.2 Describe the general trend in the change in progesterone levels in the woman's blood during the early stages of progesterone levels in the woman's blood during the early stages of pregnancy. (1)
- 2.1.3 Describe the negative feedback mechanism that occurs between progesterone and FISH during pregnancy. (2)
- 2.1.4 State the importance of the negative feedback mechanism described in QUESTION 2.1.3. (1)
- 2.1.5 Calculate the percentage increase in progesterone levels between week 4 and week 14. Show ALL calculations. (3)
- 2.1.6 The woman's progesterone level in week 16 was 25 ng/ml.

(a) Explain why this woman should be concerned about the decrease in progesterone levels. (2)

(b) Suggest ONE way in which this problem could possibly be treated by a doctor. (1)

(12)

2.3 The diagram below represents a part of the human ear.

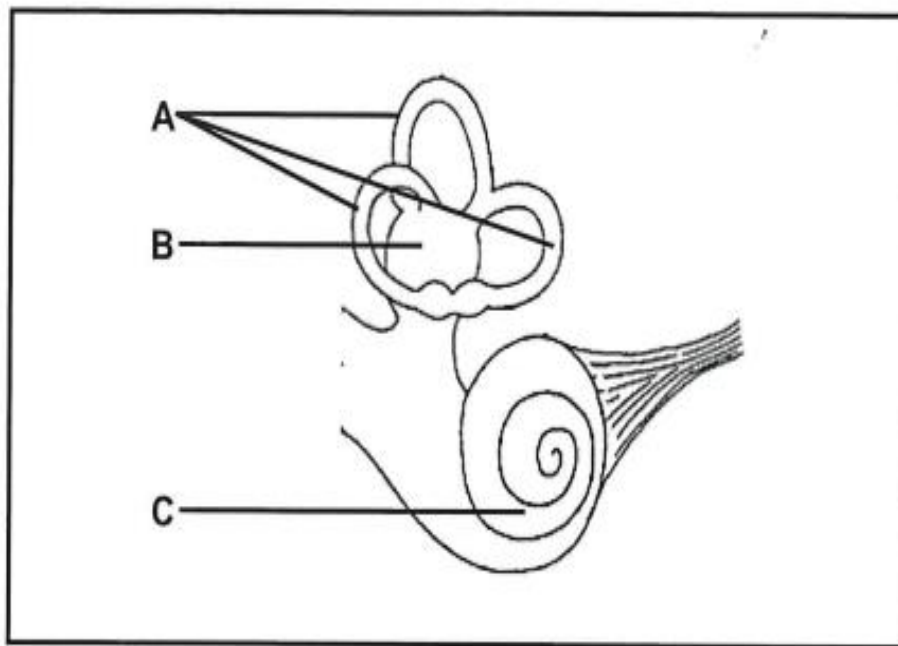

2.3.1 Name all the parts making up part A. (3)

2.3.2 Explain TWO ways in which part A in the diagram is structurally suited to maintain balance. (6)

(9)

2.4 The diagram below shows the structure of the human eye.

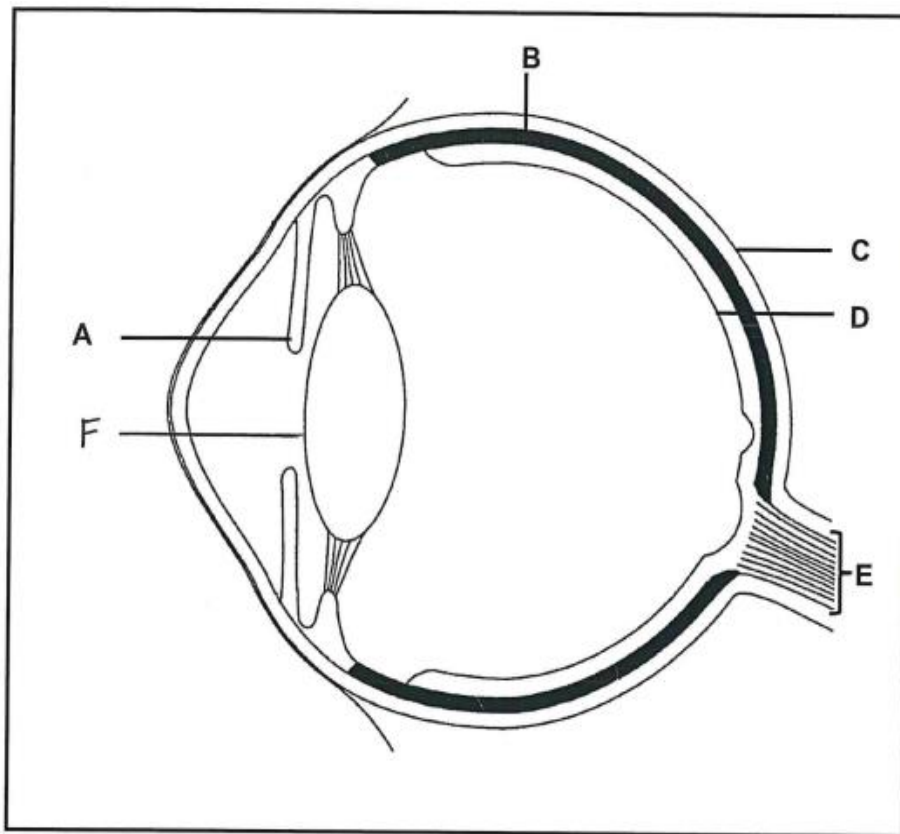

2.4.1 Identify part:

(a) **B** (1)

(b) **E** (1)

2.4.2 Name structure **F**. Explain fully the circumstances under which it will change its shape to become more flattened.

Explain the process involved in flattening/ elongating the lens. (6)

2.4.3 Explain how part **A** protects the eye from bright light entering and damaging part **D**. (4)

2.4.4 Give the function of part **C**. (1)

**(13)**

2.5 Study the diagram of a phase during meiosis below.

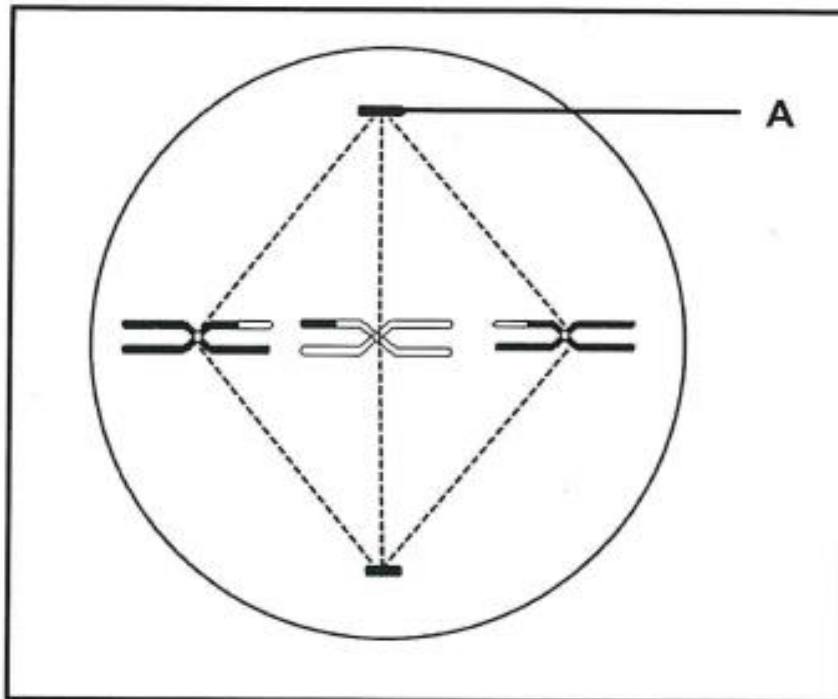

- 2.5.1 Identify part **A**. (1)
- 2.5.2 Identify the phase represented in the diagram. (1)
- 2.5.3 Explain your answer to QUESTION 2.5.2. (2)
- 2.5.4 Explain how the phase identified in QUESTION 2.5.2 contributes to variation in the gametes. (2)
- 2.5.5 Draw the phase which occurs directly after the phase in 2.5 above. (3)
- (9)**

### QUESTION 3

3.1 Study the graph below of a menstrual cycle and the influence of the different hormones on it.

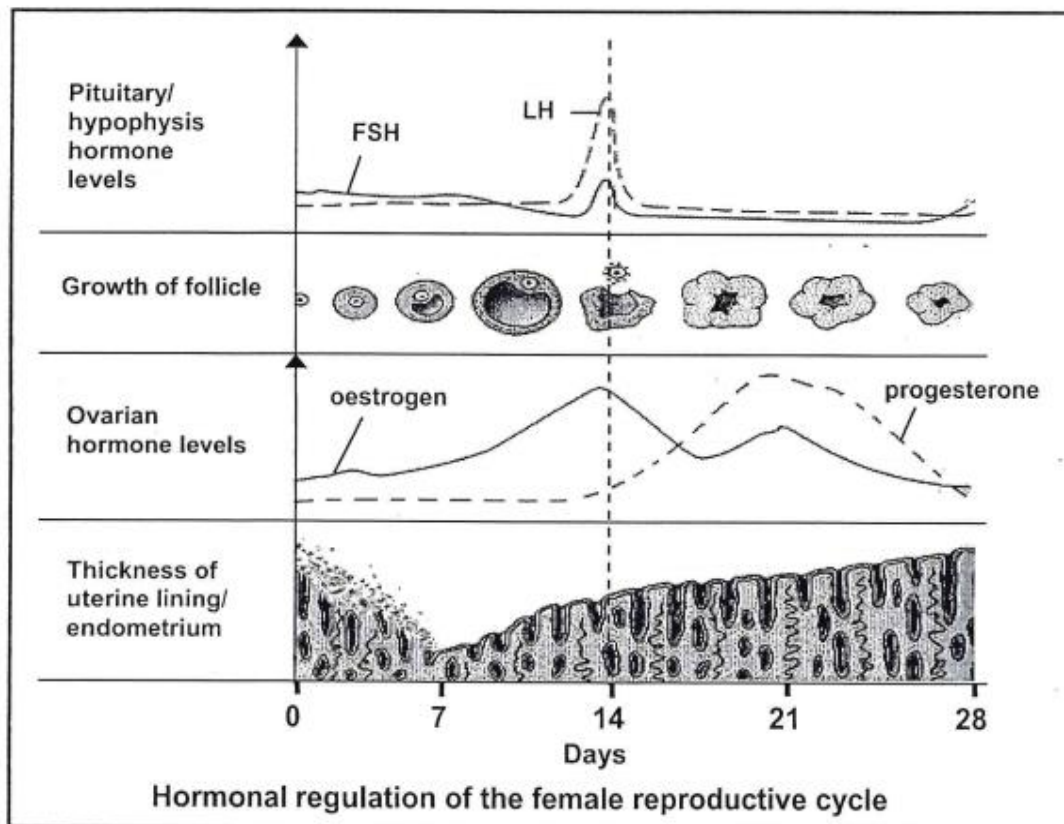

- 3.1.1 Between which days does menstruation take place? (1)
- 3.1.2 On which day does ovulation take place? (1)
- 3.1.3 State ONE function of FSH during the menstrual cycle. (1)
- 3.1.4 Describe the functional relationship between progesterone and FSH. (2)
- 3.1.5 Account for the change in the thickness of the endometrial lining between day 14 and day 21. (2)
- 3.1.6 Did fertilisation take place within the 28- day cycle illustrated in the graph? (1)
- 3.1.7 Give TWO reasons for your answer to QUESTION 3.1.6. (2)

**(10)**

3.2 Haemophilia is sex-linked disease caused by the presence of a recessive allele ( $X^h$ ). A normal father and heterozygous mother have children.

3.2.1 Represent a genetic cross to determine the possible genotypes and phenotypes of the children of the parents mentioned in QUESTION 3.2 (6)

3.2.2 What are the chances of the parents having a child that will be a haemophiliac male? (2)

3.2.3 Explain why the father is not a carrier for haemophilia. (2)

**(10)**

3.3 Study the diagram of a reflex arc below

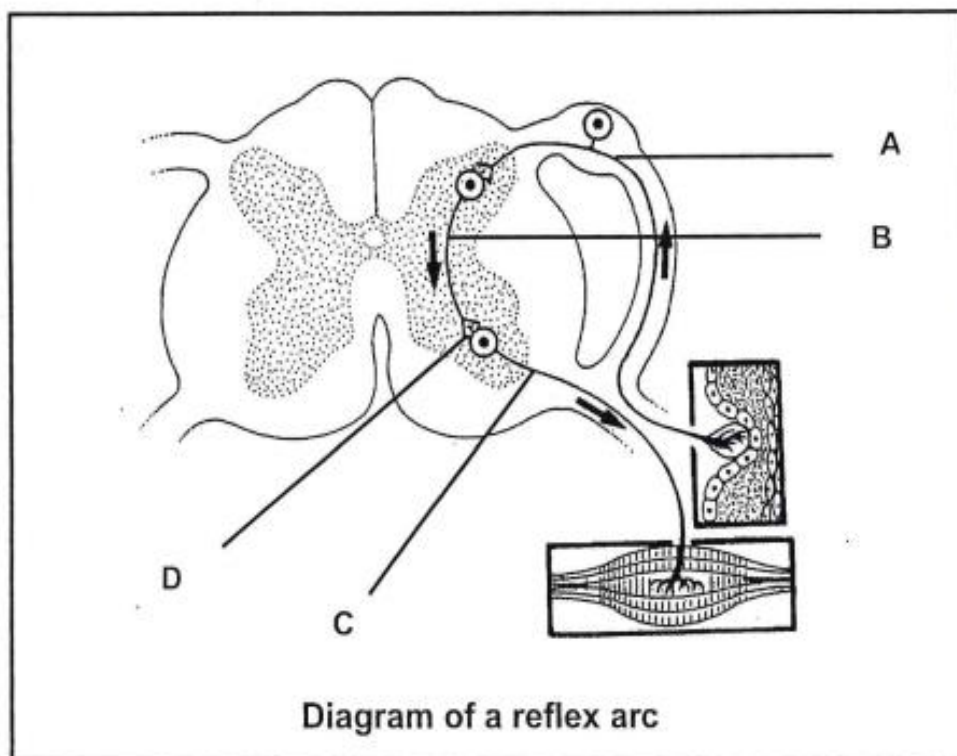

3.3.1 Write down, in the correct order, the LETTERS ONLY of the neurons involved from the time a stimulus is received until a response takes place. (3)

3.3.2 Explain the consequences for a reflex action if neuron A is damaged. (2)

3.3.3 Draw a labelled diagram to represent the structure of neuron C. (5)

**(10)**