

Hillcrest High School

PHYSICAL SCIENCE P2 JUNE 2024

Grade 11

MARKS: 150
TIME: 3 Hours

EXAMINER: Mrs J. Knox-Whitehead
MODERATOR: Ms N. Badenhorst

Instructions

1. Answer ALL the questions.
2. This question paper consists of TWO sections:
3. SECTION A (20)
SECTION B (130)

Answer SECTIONS A and B in the ANSWER BOOK.
4. Non-programmable calculators may be used.
5. Appropriate mathematical instruments may be used.
6. Number the answers correctly according to the numbering system used in this question paper.
7. Data sheets and a periodic table are attached for your use.
8. Give brief motivations, discussions, et cetera where required.
9. Numbers must be rounded off to **two decimal** places.

SECTION A**QUESTION 1: MULTIPLE CHOICE QUESTIONS**

Four options are provided as possible answers to the following questions. Each question has only ONE correct answer. Write only the letter (A – D) next to the question number (1.1 – 1.10) in the ANSWER BOOK.

- 1.1 HI has a higher boiling point than HCl. Which statement is a CORRECT explanation of this observation?
- A The chloride ion is a larger ion than the iodide ion.
 - B The molar mass of HI is smaller than the molar mass of HCl.
 - C There are more electrons in HI than in HCl.
 - D Hydrogen bonding is present in HI. (2)
- 1.2 For which ONE of the following bonds is the difference in electronegativity the GREATEST?
- A C – O
 - B C – H
 - C C – Br
 - D H – F (2)
- 1.3 Consider the four solutions below. Which of these solutions is a dilute, weak acid?
- A 0,1 mol.dm⁻³ HCl solution
 - B 5 mol.dm⁻³ CH₃COOH solution
 - C 0,5 mol.dm⁻³ oxalic acid solution
 - D 0,1 mol.dm⁻³ NaOH solution (2)

1.4 The graph below shows the change in potential energy for the reaction:

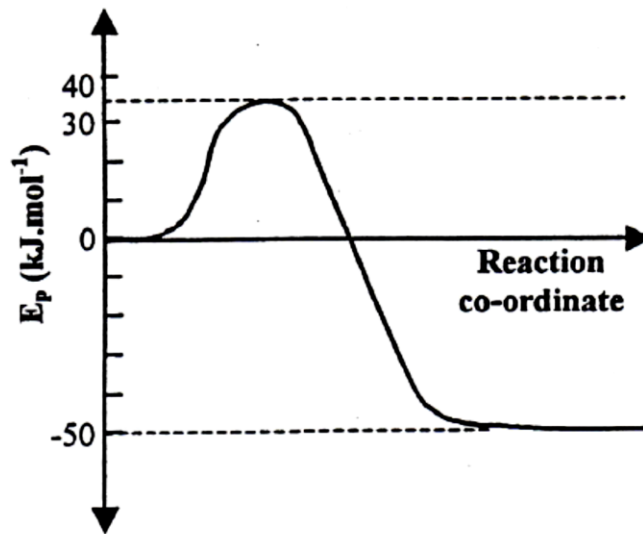

The activation energy, in kJ.mol^{-1} , for the reverse reaction is ...

- A 35
- B 60
- C 85
- D -50

(2)

1.5 The energy distribution diagrams for particles in a fixed mass of gas at two different temperatures, T_1 and T_2 , are shown below:

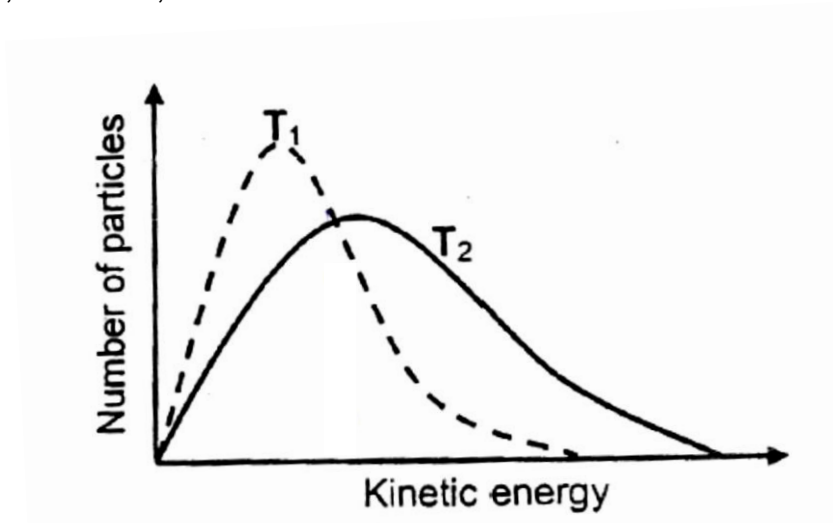

Which one of the following is the correct interpretation of the diagrams as the temperature of the gas changes from T_1 to T_2 ?

	ACTIVATION ENERGY	NUMBER OF EFFECTIVE COLLISIONS
A	Remains the same	Increases
B	Decreases	Decreases
C	Decreases	Increases
D	Remains the same	Decreases

(2)

- 1.6 In a titration involving HCl and KOH , as shown in the sketch below, a learner accidentally exceeds the endpoint.

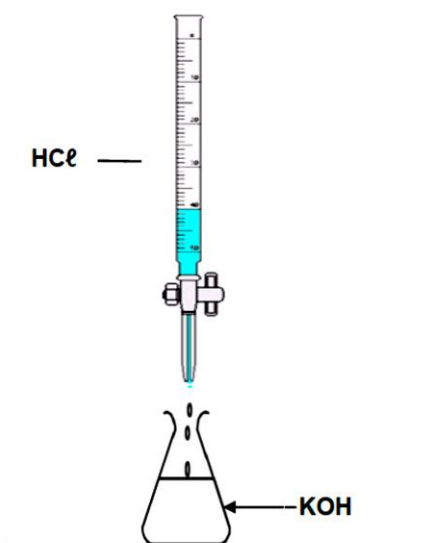

Which ONE of the following is correct for the solution now in the conical flask?

- A $[\text{H}^+] > [\text{OH}^-]$ and $\text{pH} > 7$
- B $[\text{H}^+] < [\text{OH}^-]$ and $\text{pH} > 7$
- C $[\text{H}^+] < [\text{OH}^-]$ and $\text{pH} < 7$
- D $[\text{H}^+] > [\text{OH}^-]$ and $\text{pH} < 7$

(2)

- 1.7 In which one of the following pairs of substances is the oxidation number of sulfur the same?

- A SO_2 and SO_3
- B SO_3 and H_2SO_4
- C H_2S and S
- D SO_3 and H_2SO_3

(2)

1.8 Consider the balanced equation for the reaction below:

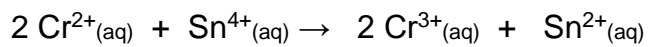

The OXIDISING AGENT is...

- A $\text{Cr}^{2+}(\text{aq})$
- B $\text{Cr}^{3+}(\text{aq})$
- C $\text{Sn}^{2+}(\text{aq})$
- D $\text{Sn}^{4+}(\text{aq})$

(2)

1.9 An electrochemical cell is set up under standard conditions. The cell notation for the cell is given below.

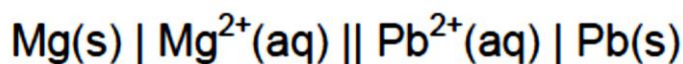

The cell is now connected in a circuit. Which ONE of the graphs below BEST represents the concentrations of the electrolytes after a long time?

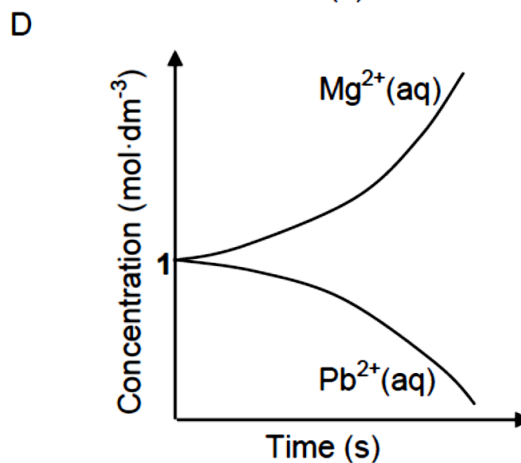
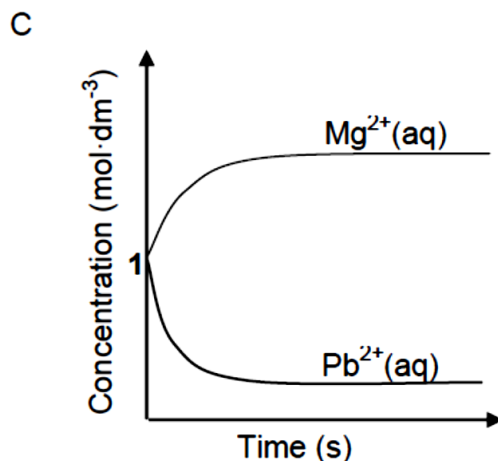
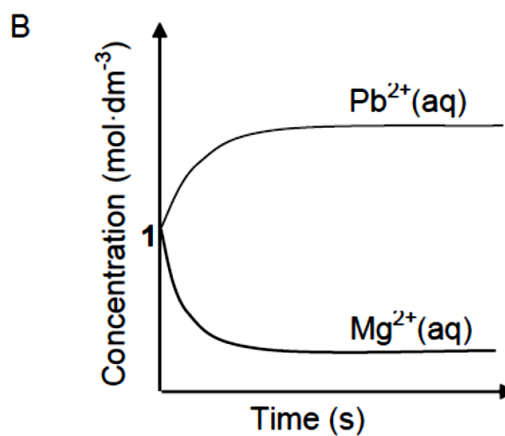
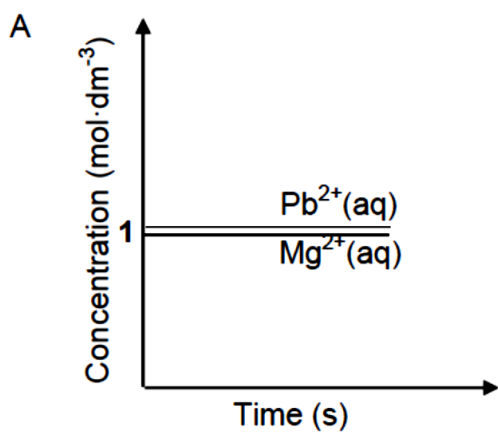

(2)

1.10 The simplified diagrams below represent two electrochemical cells using electrolytes of equal concentrations and identical batteries.

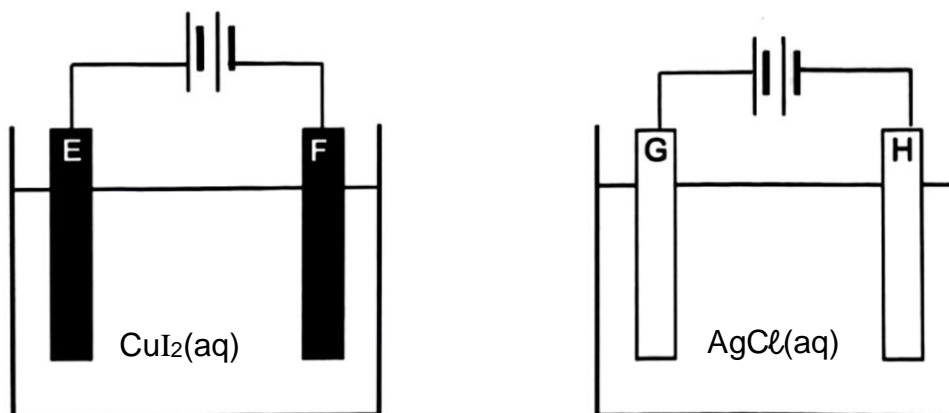

The electrode that shows the LARGEST increase in mass per unit time is:

- A E
- B F
- C G
- D H

(2)

[2 x 10 = 20]

SECTION B

Question 2

- 2.1 Nitrogen and oxygen form a series of oxides with the general formula N_xO_y . One of these compounds contains 36,80% nitrogen and 63,20% oxygen. Determine the empirical formula of this compound. (5)
- 2.2 Calculate the mass (in grams) of nitrogen present in 10 g of ammonium nitrate, (NH_4NO_3) . (3)
- 2.3 Candle wax burns in oxygen to form carbon dioxide and water according to the following balanced equation:

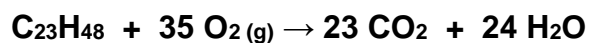

In one such reaction, $4,816 \times 10^{22}$ molecules of candle wax reacts with 3 moles of oxygen.

- 2.3.1 Define the term *limiting reagent*. (2)

- 2.3.2 Determine by calculation which substance is the limiting reagent. (4)
- 2.3.3 Calculate the MAXIMUM mass of water that can be produced. (4)
- 2.3.4 It is found that the percentage yield of carbon dioxide is 90%. Calculate the ACTUAL volume of CO₂ collected if the molar volume of the gas is 23,2 dm³ at 27°C. (4)
- 2.3.5 If the pressure of the gas at the ACTUAL volume (calculated in QUESTION 2.3.4) is equal to 119,39 kPa, use Boyle's law to calculate what the pressure would be if the volume was decreased to 0,01 m³ while keeping the temperature constant. (4)

[26]**Question 3**

Grade 11 learners want to prepare a standard solution of oxalic acid (H₂C₂O₄). They use 15,75 g of hydrated oxalic acid crystals (H₂C₂O₄.2H₂O) to make a solution of concentration 0,5 mol.dm⁻³. They prepare the solution in a volumetric flask. They have 250 cm³, 500 cm³, and 1 dm³ volumetric flasks available.

- 3.1 Define *concentration*. (2)
- 3.2 Which volumetric flask should they use? (Show by calculation how you arrived at your answer.) (4)
- 3.3 The learners wish to change the concentration of a small amount of this acid to 0,2 mol.dm⁻³. To do this, they place 25 cm³ of the acid solution prepared above in a beaker and add water to it. How much water must be added to the acid to give the required concentration of 0,2 mol.dm⁻³? (4)

[10]

Question 4

A group of learners use the reaction between calcium carbonate and excess hydrochloric acid to investigate one of the factors that influence reaction rate. They use the apparatus shown below:

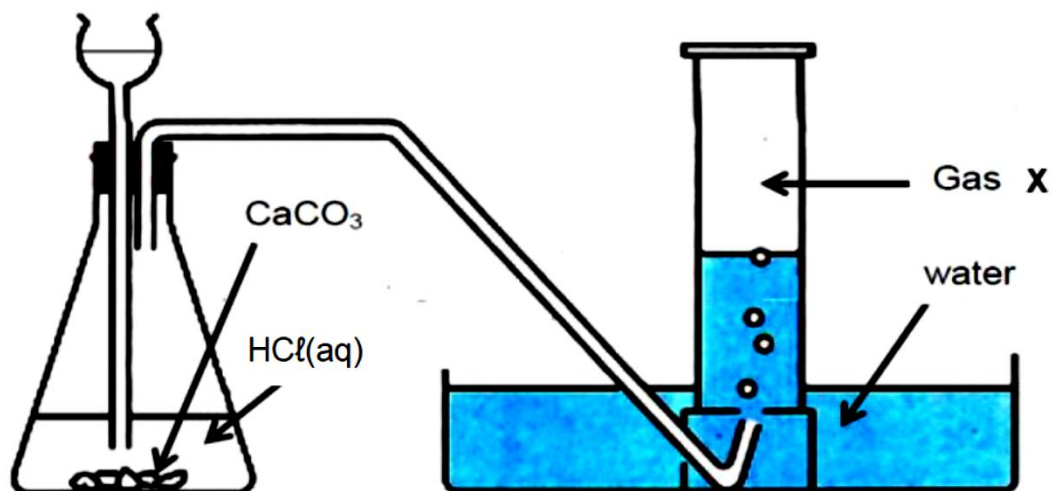

The reaction that takes place is represented by the following chemical equation:



- 4.1 Identify the gas X. (1)
- 4.2 Two experiments were conducted using the apparatus shown above. The conditions for each experiment are shown in the table below:

Experiment	Mass of CaCO ₃ (s)(g)	State of division of CaCO ₃ (s)	Concentration of HCl (mol·dm ⁻³)	Temperature of HCl(aq)(°C)
1	4	lumps	0,2	40
2	4	lumps	0,4	40

- 4.2.1 Define the term *reaction rate* in terms of this investigation. (2)
- 4.2.2 Write down the independent variable for this investigation. (1)
- 4.2.3 Give a reason why the learners must use equal masses and the same state of division of CaCO₃(s). (1)
- 4.3 The learners observe that the reaction rate is HIGHER in experiment 2 than in experiment 1.
- 4.3.1 Use the Collision Theory to explain this observation. (3)
- 4.3.2 Refer to experiment 2 and calculate the volume of hydrochloric acid (in cm³) required to react with the given amount of CaCO₃(s). (4)

4.4 The results from experiment 1 were collected and plotted on the graph below:

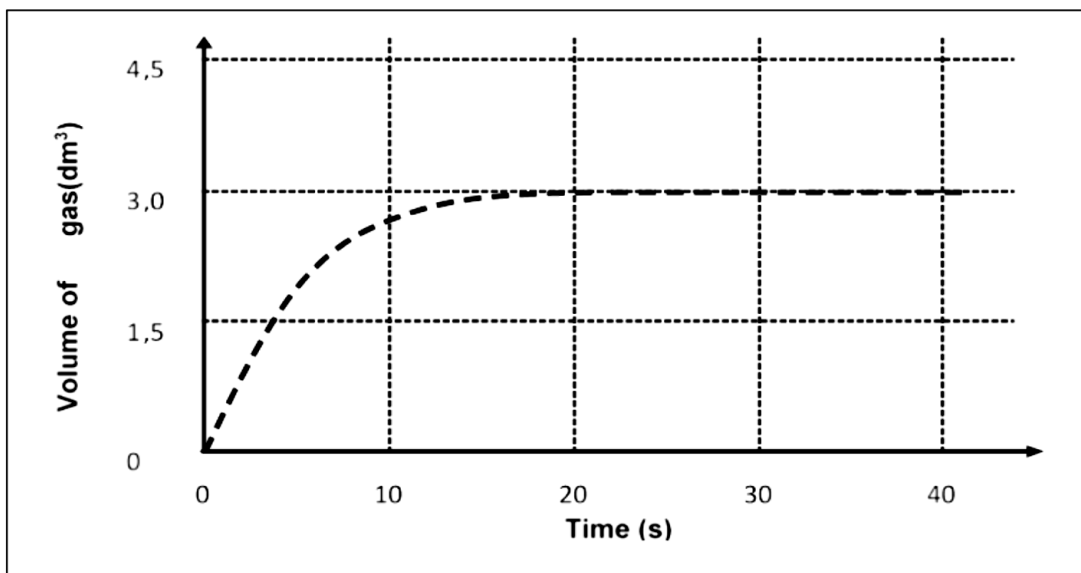

4.4.1 Calculate the average rate of reaction (in $\text{dm}^3 \cdot \text{s}^{-1}$) for experiment 1 over the first 20s. (3)

4.4.2 Redraw the above graph of experiment 1 and, on the same system of axes, sketch the graph that would be obtained for experiment 2. Clearly label your graphs for each experiment. (2)

4.5 The following diagram shows a Maxwell-Boltzmann distribution curve of a gas sample at temperatures T_1 and T_2 .

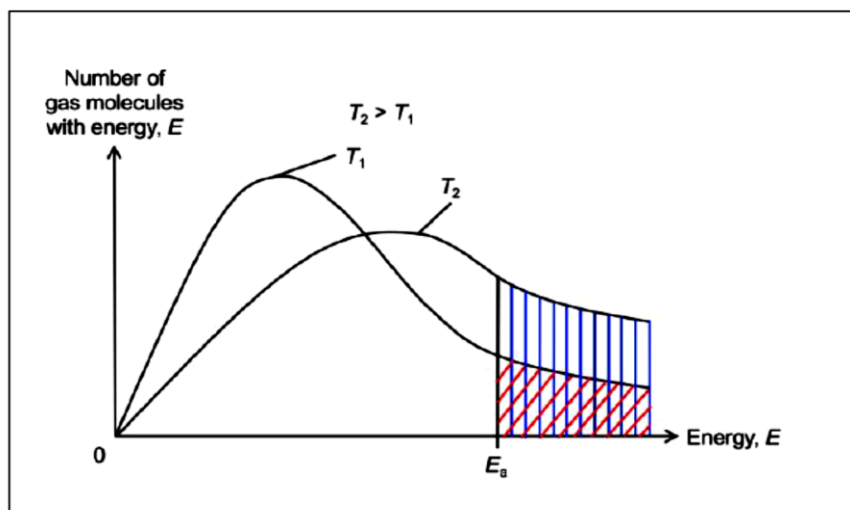

4.5.1 Which graph, T_1 or T_2 , represents the reaction carried out at a higher temperature? (1)

4.5.2 What do the shaded areas under the graph represent? (1)

4.5.3 What would happen to the size of the shaded area under the graph in T_1 if a catalyst were added to the reaction? Choose from INCREASE, DECREASE or REMAIN THE SAME. (1)

[20]

Question 5

Consider the following reaction:

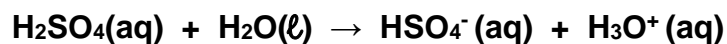

5.1 Which substance/s in the above equation can act as an ampholyte? (2)

5.2 A solution of hydrochloric acid has a concentration of $0,1 \text{ mol.dm}^{-3}$.

5.2.1 Define a *strong acid*. (2)

5.2.2 Calculate the pH of this solution. (3)

5.3 A flask contains 200 cm^3 of an aqueous solution of sodium hydroxide (NaOH) of concentration $0,1 \text{ mol.dm}^{-3}$. To this flask, 50 cm^3 of an aqueous solution of barium hydroxide, $\text{Ba}(\text{OH})_2$, of UNKNOWN concentration is added, giving a total volume of 250 cm^3 .

In a titration, 20 cm^3 of this mixture is completely neutralised by 30 cm^3 of a hydrochloric acid solution of concentration $0,1 \text{ mol.dm}^{-3}$.

The ionic reaction is represented by the following equation:

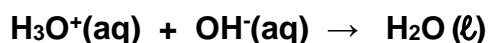

5.3.1 What is the pH of the solution when the endpoint of the titration is reached? Choose from LESS THAN 7, GREATER THAN 7 or EQUAL TO 7. (1)

5.3.2 Calculate the number of moles of hydroxide ions (OH^-) present in 20 cm^3 of the mixture of sodium hydroxide and barium hydroxide solutions. (4)

5.3.3 Calculate the initial concentration of the barium hydroxide, $\text{Ba}(\text{OH})_2$, solution that was added to the solution of sodium hydroxide. (7)

[19]

Question 6

Study the reaction below:

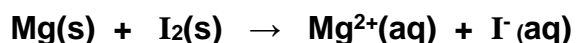

- 6.1 Define *reducing agent* in terms of oxidation numbers. (2)
- 6.2 Identify the reducing agent in the above reaction. (1)
- 6.3 Write down the FORMULA of the substance that is reduced. (1)
- 6.4 Write down the:
- 6.4.1 oxidation half reaction (2)
- 6.4.2 reduction half reaction (2)

[8]

Question 7

The diagram below shows an electrochemical cell set up under standard conditions, with electrodes of aluminium (Al) and tin (Sn(II)) respectively. The salt bridge contains a solution of potassium nitrate (KNO₃).

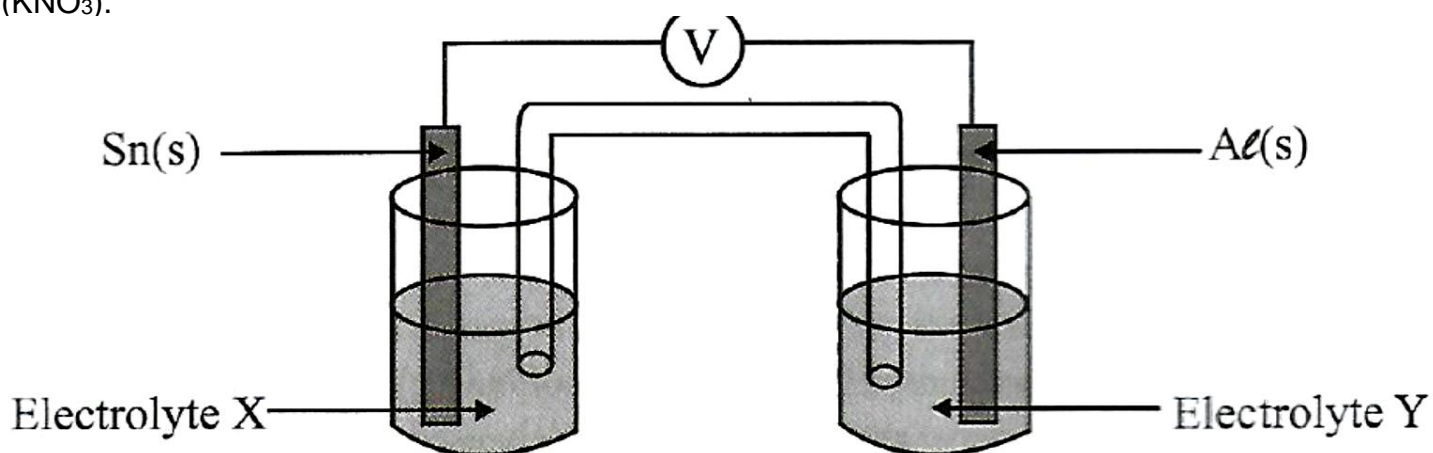

- 7.1 Write down the formula for a suitable electrolyte to use as electrolyte X. (1)
- 7.2 Write down the half reaction that occurs at the cathode of this cell. (2)
- 7.3 Calculate the reading on the voltmeter at 25°C. (4)
- 7.4 What is the concentration of electrolyte Y when the cell is connected? (1)
- 7.5 Write down the ion that will move from the salt bridge towards the Sn(s) electrode. (1)

7.6 For each of the following, say whether it will INCREASE, DECREASE or REMAIN THE SAME as time passes:

7.6.1 Voltmeter reading (1)

7.6.2 Concentration of the metal ions in electrolyte X (1)

7.6.3 Mass of the Al(s) electrode (1)

[12]

Question 8

The diagram below shows an electrolytic cell used to electroplate iron spoons with copper.

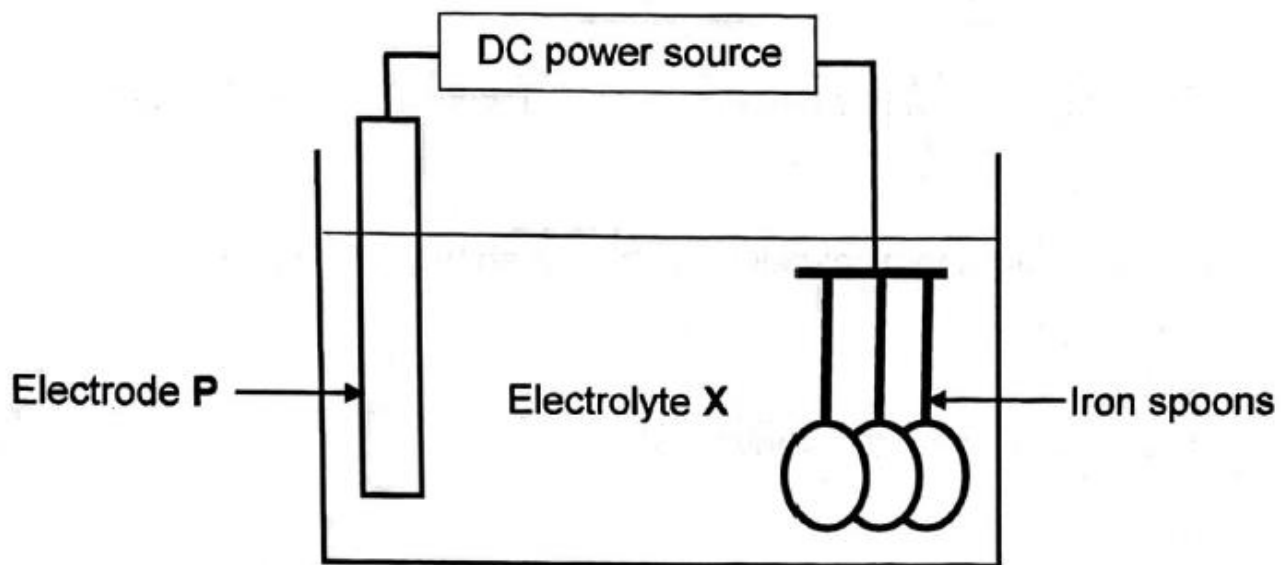

8.1 Define the term *electrolyte*. (2)

8.2 State the energy conversion that takes place in this cell. (1)

8.3 Identify the anode in this cell. Choose between electrode **P** and the iron spoons. (1)

8.4 Write down the equation for the half reaction that results in the plating of the spoons. (2)

8.5 The mass change at electrode **P** from the time the cell was first set up has been plotted in the graph below:

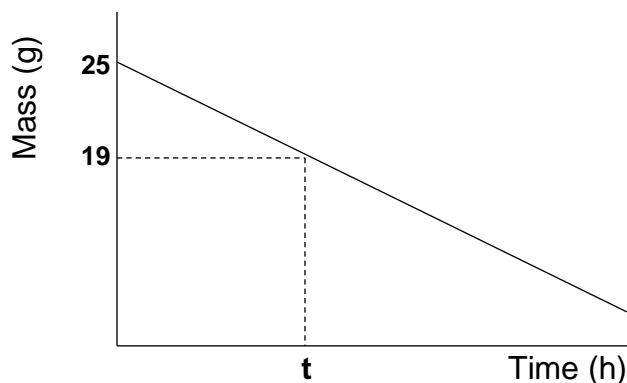

8.5.1 Calculate the number of electrons that have been transferred up to the point shown in the graph as time, t . (6)

8.5.2 Electrolyte **X** is blue in colour. Describe the intensity of this colour at time, t , compared to the intensity when the cell was first set up.

Choose from DARKER BLUE, PALER BLUE or REMAINS THE SAME.

Give a reason for your answer. (2)

8.6 The copper used in this electrolytic cell is NOT PURE. It contains a small percentage of zinc. It is observed that the iron spoons are not coated with zinc. Explain this observation in terms of the relative oxidising strengths of the substances. (2)

[16]

Question 9

Consider the following molecules and answer the questions that follow:



9.1 Define the term *covalent bond*. (2)

9.2 Consider the NH₃ molecule.

9.2.1 Draw the Lewis structure for NH₃. (2)

9.2.2 Name the intermolecular forces found between these molecules. (1)

9.2.3 Explain why the H⁺ ion can form a dative covalent bond with NH₃. (2)

9.3 Indicate whether the covalent **bonds** in the following molecules are POLAR or NON-POLAR.

- 9.3.1 HCl (1)
 9.3.2 N₂ (1)
 9.3.3 CO₂ (1)

9.4 Consider the CF₄ molecule.

9.4.1 Name the shape of this molecule. (1)

9.4.2 Explain why the bonds in this molecule are POLAR while the molecule is NON-POLAR. (3)
[14]

Question 10

A group of learners investigated the relationship between bond length and bond energy. The data collected theoretically is shown in the table below.

BOND	BOND LENGTH (pm)	BOND ENERGY (kJ.mol ⁻¹)
C≡C	120	839
C=O	123	804
O=O	121	498
C–C	154	348
H–O	96	463
H–C	109	413

10.1 Define the term *bond length*. (2)

10.2 Apart from bond length, name TWO other factors that influence bond energy. (2)

10.3 Use the table above to determine which one of the following bond energies would be correct for the C=C bond?
 Choose from **880 kJ.mol⁻¹**, **540 kJ.mol⁻¹** or **320 kJ.mol⁻¹**. (1)
[5]

Total 150

TABLE 4A: STANDARD REDUCTION POTENTIALS
TABEL 4A: STANDAARD- REDUKSIEPOTENSIALE

Half-reactions/Halfreaksies	E° (V)
$F_2(g) + 2e^- = 2F^-$	+ 2,87
$Co^{3+} + e^- = Co^{2+}$	+ 1,81
$H_2O_2 + 2H^+ + 2e^- = 2H_2O$	+1,77
$MnO_4^- + 8H^+ + 5e^- = Mn^{2+} + 4H_2O$	+ 1,51
$Cl_2(g) + 2e^- = 2Cl^-$	+ 1,36
$Cr_2O_7^{2-} + 14H^+ + 6e^- = 2Cr^{3+} + 7H_2O$	+ 1,33
$O_2(g) + 4H^+ + 4e^- = 2H_2O$	+ 1,23
$MnO_2 + 4H^+ + 2e^- = Mn^{2+} + 2H_2O$	+ 1,23
$Pt^{2+} + 2e^- = Pt$	+ 1,20
$Br_2(l) + 2e^- = 2Br^-$	+ 1,07
$NO_3^- + 4H^+ + 3e^- = NO(g) + 2H_2O$	+ 0,96
$Hg^{2+} + 2e^- = Hg(l)$	+ 0,85
$Ag^+ + e^- = Ag$	+ 0,80
$NO_3^- + 2H^+ + e^- = NO_2(g) + H_2O$	+ 0,80
$Fe^{3+} + e^- = Fe^{2+}$	+ 0,77
$O_2(g) + 2H^+ + 2e^- = H_2O_2$	+ 0,68
$I_2 + 2e^- = 2I^-$	+ 0,54
$Cu^+ + e^- = Cu$	+ 0,52
$SO_2 + 4H^+ + 4e^- = S + 2H_2O$	+ 0,45
$2H_2O + O_2 + 4e^- = 4OH^-$	+ 0,40
$Cu^{2+} + 2e^- = Cu$	+ 0,34
$SO_4^{2-} + 4H^+ + 2e^- = SO_2(g) + 2H_2O$	+ 0,17
$Cu^{2+} + e^- = Cu^+$	+ 0,16
$Sn^{4+} + 2e^- = Sn^{2+}$	+ 0,15
$S + 2H^+ + 2e^- = H_2S(g)$	+ 0,14
$2H^+ + 2e^- = H_2(g)$	0,00
$Fe^{3+} + 3e^- = Fe$	- 0,06
$Pb^{2+} + 2e^- = Pb$	- 0,13
$Sn^{2+} + 2e^- = Sn$	- 0,14
$Ni^{2+} + 2e^- = Ni$	- 0,27
$Co^{2+} + 2e^- = Co$	- 0,28
$Cd^{2+} + 2e^- = Cd$	- 0,40
$Cr^{3+} + e^- = Cr^{2+}$	- 0,41
$Fe^{2+} + 2e^- = Fe$	- 0,44
$Cr^{3+} + 3e^- = Cr$	- 0,74
$Zn^{2+} + 2e^- = Zn$	- 0,76
$2H_2O + 2e^- = H_2(g) + 2OH^-$	- 0,83
$Cr^{2+} + 2e^- = Cr$	- 0,91
$Mn^{2+} + 2e^- = Mn$	- 1,18
$Al^{3+} + 3e^- = Al$	- 1,66
$Mg^{2+} + 2e^- = Mg$	- 2,36
$Na^+ + e^- = Na$	- 2,71
$Ca^{2+} + 2e^- = Ca$	- 2,87
$Sr^{2+} + 2e^- = Sr$	- 2,89
$Ba^{2+} + 2e^- = Ba$	- 2,90
$Cs^+ + e^- = Cs$	- 2,92
$K^+ + e^- = K$	- 2,93
$Li^+ + e^- = Li$	- 3,05

Increasing oxidising ability/Toenemende oksiderende vermoë

Increasing reducing ability/Toenemende reduserende vermoë

TABLE 4B: STANDARD REDUCTION POTENTIALS
TABEL 4B: STANDAARD- REDUKSIEPOTENSIALE

Half-reactions/Halfreaksies	E^{\ominus} (V)
$\text{Li}^+ + e^- = \text{Li}$	-3,05
$\text{K}^+ + e^- = \text{K}$	-2,93
$\text{Cs}^+ + e^- = \text{Cs}$	-2,92
$\text{Ba}^{2+} + 2e^- = \text{Ba}$	-2,90
$\text{Sr}^{2+} + 2e^- = \text{Sr}$	-2,89
$\text{Ca}^{2+} + 2e^- = \text{Ca}$	-2,87
$\text{Na}^+ + e^- = \text{Na}$	-2,71
$\text{Mg}^{2+} + 2e^- = \text{Mg}$	-2,36
$\text{Al}^{3+} + 3e^- = \text{Al}$	-1,66
$\text{Mn}^{2+} + 2e^- = \text{Mn}$	-1,18
$\text{Cr}^{2+} + 2e^- = \text{Cr}$	-0,91
$2\text{H}_2\text{O} + 2e^- = \text{H}_2(\text{g}) + 2\text{OH}^-$	-0,83
$\text{Zn}^{2+} + 2e^- = \text{Zn}$	-0,76
$\text{Cr}^{3+} + 3e^- = \text{Cr}$	-0,74
$\text{Fe}^{2+} + 2e^- = \text{Fe}$	-0,44
$\text{Cr}^{3+} + e^- = \text{Cr}^{2+}$	-0,41
$\text{Cd}^{2+} + 2e^- = \text{Cd}$	-0,40
$\text{Co}^{2+} + 2e^- = \text{Co}$	-0,28
$\text{Ni}^{2+} + 2e^- = \text{Ni}$	-0,27
$\text{Sn}^{2+} + 2e^- = \text{Sn}$	-0,14
$\text{Pb}^{2+} + 2e^- = \text{Pb}$	-0,13
$\text{Fe}^{3+} + 3e^- = \text{Fe}$	-0,06
$2\text{H}^+ + 2e^- = \text{H}_2(\text{g})$	0,00
$\text{S} + 2\text{H}^+ + 2e^- = \text{H}_2\text{S}(\text{g})$	+0,14
$\text{Sn}^{4+} + 2e^- = \text{Sn}^{2+}$	+0,15
$\text{Cu}^{2+} + e^- = \text{Cu}^+$	+0,16
$\text{SO}_4^{2-} + 4\text{H}^+ + 2e^- = \text{SO}_2(\text{g}) + 2\text{H}_2\text{O}$	+0,17
$\text{Cu}^{2+} + 2e^- = \text{Cu}$	+0,34
$2\text{H}_2\text{O} + \text{O}_2 + 4e^- = 4\text{OH}^-$	+0,40
$\text{SO}_2 + 4\text{H}^+ + 4e^- = \text{S} + 2\text{H}_2\text{O}$	+0,45
$\text{Cu}^+ + e^- = \text{Cu}$	+0,52
$\text{I}_2 + 2e^- = 2\text{I}^-$	+0,54
$\text{O}_2(\text{g}) + 2\text{H}^+ + 2e^- = \text{H}_2\text{O}_2$	+0,68
$\text{Fe}^{3+} + e^- = \text{Fe}^{2+}$	+0,77
$\text{NO}_3^- + 2\text{H}^+ + e^- = \text{NO}_2(\text{g}) + \text{H}_2\text{O}$	+0,80
$\text{Ag}^+ + e^- = \text{Ag}$	+0,80
$\text{Hg}^{2+} + 2e^- = \text{Hg}(\ell)$	+0,85
$\text{NO}_3^- + 4\text{H}^+ + 3e^- = \text{NO}(\text{g}) + 2\text{H}_2\text{O}$	+0,96
$\text{Br}_2(\ell) + 2e^- = 2\text{Br}^-$	+1,07
$\text{Pt}^{2+} + 2e^- = \text{Pt}$	+1,20
$\text{MnO}_2 + 4\text{H}^+ + 2e^- = \text{Mn}^{2+} + 2\text{H}_2\text{O}$	+1,23
$\text{O}_2(\text{g}) + 4\text{H}^+ + 4e^- = 2\text{H}_2\text{O}$	+1,23
$\text{Cr}_2\text{O}_7^{2-} + 14\text{H}^+ + 6e^- = 2\text{Cr}^{3+} + 7\text{H}_2\text{O}$	+1,33
$\text{Cl}_2(\text{g}) + 2e^- = 2\text{Cl}^-$	+1,36
$\text{MnO}_4^- + 8\text{H}^+ + 5e^- = \text{Mn}^{2+} + 4\text{H}_2\text{O}$	+1,51
$\text{H}_2\text{O}_2 + 2\text{H}^+ + 2e^- = 2\text{H}_2\text{O}$	+1,77
$\text{Co}^{3+} + e^- = \text{Co}^{2+}$	+1,81
$\text{F}_2(\text{g}) + 2e^- = 2\text{F}^-$	+2,87

Increasing oxidising ability/Toenemende oksiderende vermoë

Increasing reducing ability/Toenemende reduserende vermoë

NAME/NAAM	SYMBOL/SIMBOOL	VALUE/WAARDE
Avogadro's constant <i>Avogadro-konstante</i>	N_A	$6,02 \times 10^{23} \text{ mol}^{-1}$
Molar gas constant <i>Molêre gaskonstante</i>	R	$8,31 \text{ J} \cdot \text{K}^{-1} \cdot \text{mol}^{-1}$
Standard pressure Standaarddruk	p^θ	$1,013 \times 10^5 \text{ Pa}$
Molar gas volume at STP <i>Molêre gasvolume by STD</i>	V_m	$22,4 \text{ dm}^3 \cdot \text{mol}^{-1}$
Standard temperature Standaardtemperatuur	T^θ	273 K

TABLE 2: FORMULAE/TABEL 2: FORMULES

$\frac{m}{n} = M$	$\frac{N}{n} = N_A$
$\frac{n}{c} = V$ or/of $\frac{m}{c} = MV$	$\frac{V}{n} = V_m$
$\frac{C_a V_a}{C_b V_b} = \frac{n_a}{n_b}$	$\text{pH} = -\log[\text{H}_3\text{O}^+]$
$K_w = [\text{H}_3\text{O}^+][\text{OH}^-] = 1 \times 10^{-14}$ at/by 298 K	
$E_{\text{cell}}^\theta = E_{\text{cathode}}^\theta - E_{\text{anode}}^\theta / E_{\text{sel}}^\theta = E_{\text{katode}}^\theta - E_{\text{anode}}^\theta$	
or/of $E_{\text{cell}}^\theta = E_{\text{reduction}}^\theta - E_{\text{oxidation}}^\theta / E_{\text{sel}}^\theta = E_{\text{reduksie}}^\theta - E_{\text{oksidasie}}^\theta$	
or/of $E_{\text{cell}}^\theta = E_{\text{oxidising agent}}^\theta - E_{\text{reducing agent}}^\theta / E_{\text{sel}}^\theta = E_{\text{oksideermiddel}}^\theta - E_{\text{reduseermiddel}}^\theta$	

$\frac{p_1 V_1}{T_1} = \frac{p_2 V_2}{T_2}$	$pV = nRT$
---	------------

