



Hillcrest High School

Mathematics

November 2011

Grade 9

Examiner: Mrs J Leuschke

Moderator: Miss Badenhorst

Instructions to candidates:

This paper consists of 7 pages with formulas on the last page.

Answer all questions on the paper provided.

You may not share calculators with anyone during the exam.

Write the name and model of your calculator on the top of your answer paper.

Round all answers off correctly to 2 decimal places unless otherwise stated.

Write your teachers name on the top of your answer paper.

Number your answers correctly according to the numbers used in this question paper.

Show all working out.

Draw double margins.

It is in your best interest to set your work out neatly and legibly.

Answer Question 6.1.4 and Question 9.2 on Annexure 1 and Question 12 on Annexure 2

Total: 145 marks

Question 1If $a=3$, $b=2$ and $c=-1$, find the values of

1.1 $18b - 14ac =$ (1)

1.2 $9c + 3ac^2$ (2)

1.3 $\frac{40b^2}{a^2c} =$ (2)

1.4 $\frac{b-1}{a+b} + \frac{c}{4} =$ (3)

[8]

Question 2

Solve for x:

2.1 $2x + 1 = 5$ (1)

2.2 $5(x - 8) = 8x$ (2)

2.3 $4(x - 5) + x = -40$ (3)

2.4 $\frac{2x-1}{5} = \frac{x-1}{3} + 3$ (4)

2.5 First write the equation and then solve it

2.5.1 Byron thinks of a number and then adds 8, the answer is 24. Find the number. (3)

2.5.2 Naomi multiplies a certain number by 5 and subtracts 9, the answer is -40. Find the number. (3)

[16]

Question 3

Find the product of the binomials:

3.1 $(x + 9)(x - 1)$ (2)

3.2 $(8 - 2x)(3 + x)$ (3)

3.3 $(x - 3)^2$ (3)

3.4 $3(2x + 1)(2x - 1)$ (4)

[12]

Question 4

Simplify the following without using a calculator. Leave your answer in exponential form.

4.1 $-3x^3n \times x^3m$ (2)

4.2 $2^8 \times 2^4$ (1)

4.3 $14m^4n^2o^3 \div 7m^2n^6o^{12}$ (3)

4.4 $3^3 + 3^0$ (2)

4.5 $(3e^3)^2$ (2)

4.6 $\frac{14a^3b^2c}{3def} \div \frac{7abc}{6d^3e^8f^6}$ (4)

[14]

Question 5

Factorise the following:

5.1 $2x^2 + 2xy$ (1)

5.2 $y^2 - 9$ (2)

5.3 $1 - 36a^2b^4$ (2)

5.4 $y(2z - 1) - 5(2z - 1)$ (2)

[7]

Question 66.1.1 Redraw and complete the table for the function $f(x) = 2x + 1$

X	-2	0	2
F(x)			

(2)

6.1.2 Calculate the y-intercept of the straight line $f(x) = 2x + 1$ (1)6.1.3 Calculate the x-intercept of the straight line $f(x) = 2x + 1$ (2)6.1.4 Draw the graph for $f(x) = 2x + 1$ on the graph paper provided (annexure 1) (4)

6.2 Calculate the equation for the graphs a and b

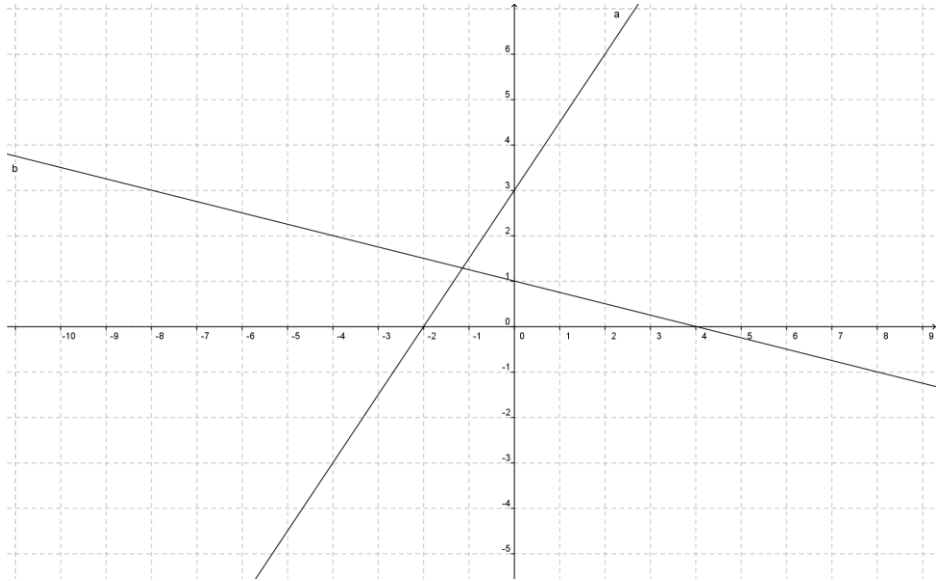

(6)
[15]

Question 7

7.1 Calculate the volume of each shape below:

7.1.1

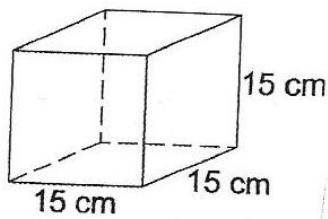

(2)

7.1.2

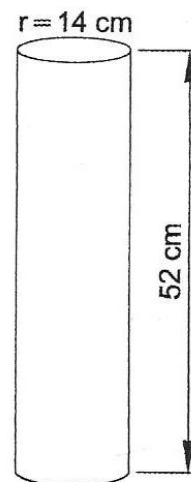

(2)

(2)

7.2.1 Calculate the length of PR

7.2.2 Calculate the area of the shape

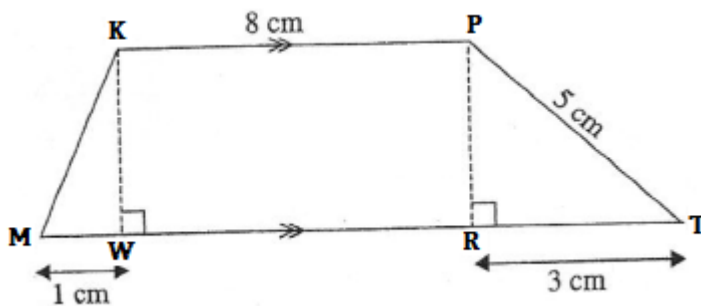

(4)

[10]

Question 8

Look at the diagram below; it represents the distribution of average monthly temperatures in a year.

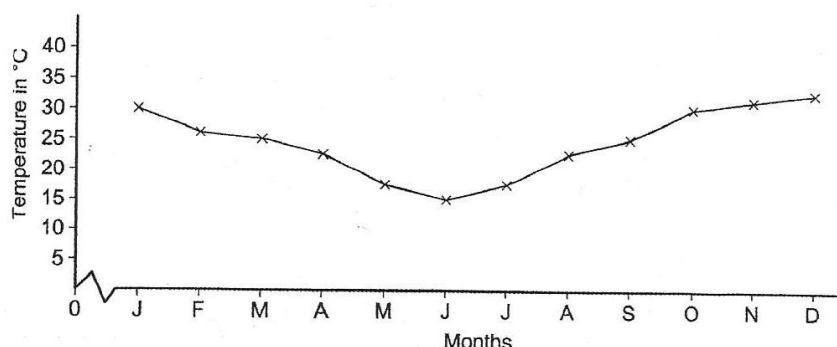

- 8.1 What is the highest temperature recorded? (1)
 - 8.2 What is the lowest temperature recorded? (1)
 - 8.3 In which month was the highest temperature recorded? (2)
 - 8.4 Is this place in the Northern Hemisphere or the Southern Hemisphere? Support your answer. (2)
 - 8.5 Calculate the range of the temperature. (2)
- [8]

Question 9

The mass in kilogram of 10 Grade 9 learners is as follows:

Busisiwe	48	Devon	45
Xoliswa	30	Jesse	35
Kirsty	35	Trent	75
Natalie	55	Robin	41
Nosipho	39	Kevin	66

- 9.1.1 Calculate is the mean mass of these learners? (3)
- 9.1.2 What is the lowest mass of these learners? (1)
- 9.1.3 What is the highest mass of these learners? (1)
- 9.1.4 Calculate the range of the data? (2)
- 9.1.5 Find the mode of the mass of these learners? (1)
- 9.1.6 Calculate the median of the mass of these learners? (2)
- 9.2 Draw a bar graph of the above data in the space provided on Annexure 1 (5)

[15]

Question 10

- 10.1 Calculate the final amount if R200 is invested for 2 years at 6% p.a. simple interest. (3)
- 10.2 Calculate the difference between investing R200 000 in a compound interest or simple interest account for 3 years at 6% p.a.? (6)
- 10.3 I borrowed R10 000 for 3 years at a rate of 3,5% compound interest per annum. Calculate the amount I have to pay back after the period of 3 years. (3)
- 10.4 You want to buy your brother a tricycle at a toy shop. It costs R350, but you get a discount of 7% on the tricycle. How much do you have to pay for the tricycle? (5)
- [17]

Question 11

- 11.1 State whether the following pairs of triangles are congruent or not. If they are congruent, write the reason for congruency in brackets.

11.1.1

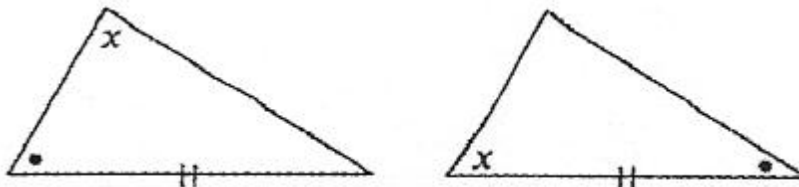

(2)

11.1.2

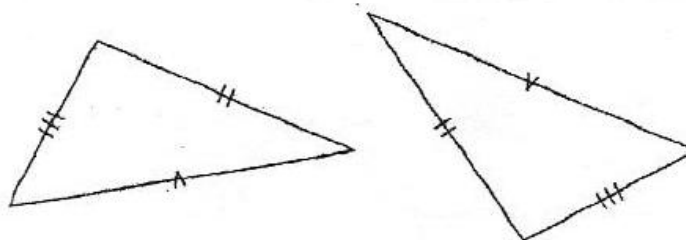

(2)

11.1.3

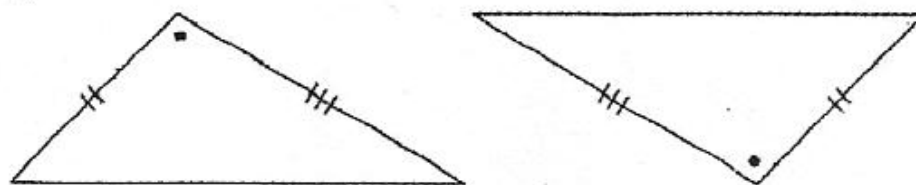

(2)

11.1.4

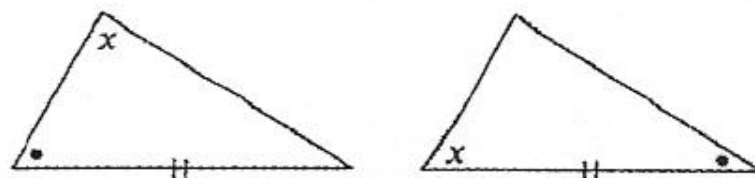

(2)

11.2 Prove that the following pair of triangles are congruent.

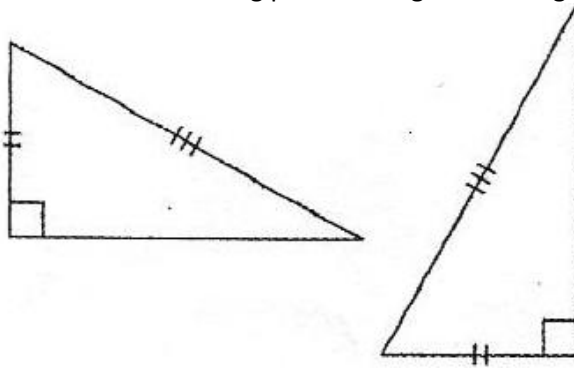

(5)
[13]

Question 12

Answer the following questions on Annexure 2

- 12.1.1 Name the Transformation that has mapped ABCD onto A'B'C'D' (1)
 - 12.2.1 Describe the above transformation in words (3)
 - 12.2 On the set of axes map A'B'C'D' onto PQRS by reflection about the y-axis (3)
 - 12.3 Rotate ABCD 90° in an anti-clockwise direction about point A. Label the new diagram LOVE (3)
- [10]

Total: 145 marks

Formula sheet

Financial Maths

$$A = P(1 + in)$$

$$A = P(1 + i)^n$$

Graphing formulas

Equation for a straight line

$$y = mx + c$$

Gradient

$$\frac{y_2 - y_1}{x_2 - x_1}$$

Area and volume

$$A = \pi r^2$$

$$A = l \times b$$

$$A = \frac{1}{2}b \times h$$

$$V = \text{area of base} \times \text{height}$$

Theorem of Pythagoras

$$a^2 + b^2 = c^2$$

Annexure 1

Question 6.1.4

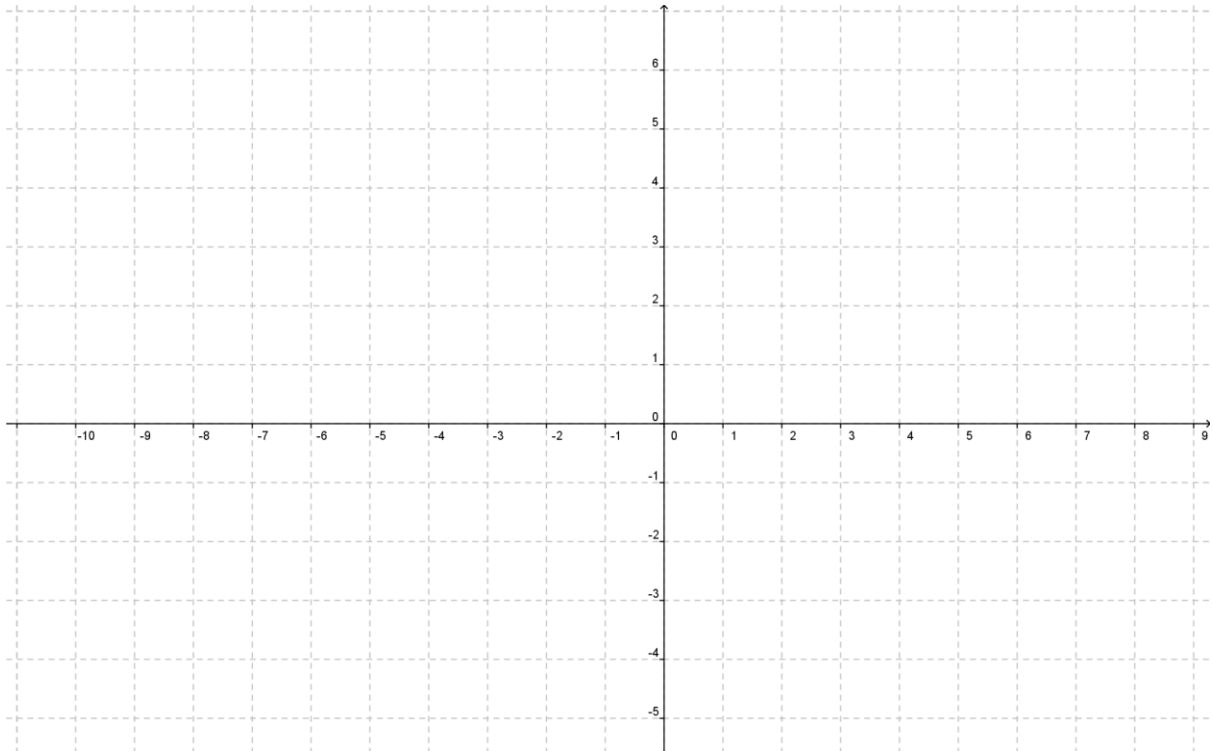

Question 9.2



Graph showing the masses of 10 learners in grade 9

Annexure 2

Question 12

