

HILLCREST HIGH SCHOOL



Grade 9 Mathematics Exam

November 2014

Examiner: D Dunlop

MARKS: 160

TIME: 2 hours

INSTRUCTIONS AND INFORMATION

Read the following instructions carefully before answering the questions.

1. This question paper consists of 14 questions.
2. Answer ALL the questions.
3. Clearly show ALL calculations, diagrams, graphs, etc. that you have used in determining your answers
4. Answers only will NOT necessarily be awarded full marks.
5. You may use an approved calculator (non-programmable and non-graphical), unless stated otherwise.
6. If necessary, round off answers to TWO decimal places, unless stated otherwise.
7. Diagrams are not necessarily drawn to scale.
8. Number the answers correctly, according to the numbering system used in this question paper.
9. Write neatly and legibly.

Section A

1. **Mental Maths** – give answers only.

1.1. Express 24 as products of powers of prime factors. (1)

1.2. Express $\frac{1}{8}$ as a decimal number. (1)

1.3. $a^0 =$ (1)

1.4. A square with an area of 64cm^2 has a side length of ___ cm. (1)

1.5. π is defined as the ratio of _____ to _____. (2)

[6]

2. **State whether the following statements are True or False**

2.1. $9x^2 - 30xy + 25y^2 = (3x - 5y)^2$ (1)

2.2. The statement in 2.1. is called a difference of two squares. (1)

2.3. In the relationship $y = -\frac{x}{4} + 3$; 'y' is known as the independent variable. (1)

2.4. Point (5;3) reflected in the y – axis is represented by the co-ordinates (-5;3)? (1)

2.5. If the gradient of a function is given as 4, it means the graph of the function goes along 4 units and up one. (1)

[5]

3. **Match the columns.** (Write just the question number and your selection e.g. 3.6 - g)

3.1.	Rational Number	a.	-3
3.2.	Natural Number	b.	$\sqrt{2}$
3.3.	Integer	c.	0
3.4.	Irrational Number	d.	1.5
3.5.	The whole number that is not a natural number	e.	3

[5]

4. Multiple Choice – Select the correct answer from the options provided. Write down only the question number and your selection.

4.1. How many Kilometres are there in $3,5 \times 10^8$ mm.

- (a) 3 500Km. (b) 35Km (c) 350Km (d) 3,5Km

4.2. $\frac{x-3}{x-4}$ will be undefined when $x =$ ____

- (a) -3. (b) 3 (c) -4 (d) 4

4.3. A mixed number is an example of a _____ number.

- (a) integer (b) natural (c) irrational (d) rational

4.4. $3 + 2 \times 5 - 3 \times 4 =$

- (a) 88. (b) 18. (c) 1. (d) 40.

4.5. Which of the following functions will form a graph perpendicular to $y = -\frac{x}{4} + 3$

- (a) $4y = \frac{48x}{3} + 12$ (b) $y = -4x + 3$
(c) $y = -\frac{x}{4} - 5$ (d) $2y = 3x + 4$ [5]

/21/

Section B

5. Expand and Collect Like Terms.

5.1. $3a(4a + 9b)$ (2) 5.2. $(x + 2)(3x^2 - 5x + 7)$ (3)

5.3. $(x - 8)^2$ (3) 5.4. $(x - 7)(x + 7)$ (3)

5.5. $(x + 9)(x - 7)$ (3) [14]

6. Factorise

- 6.1. $18x^3 + 24x^2y$ (2) 6.2. $x(x - 2) + 3(x - 2)$ (2)
6.3. $x^2 - 121$ (2) 6.4. $x^2 + 6x + 9$ (2)
6.5. $x^2 - 11x + 24$ (2) 6.6. $3x^3 + 9x^2 - 12x$ (3)
[13]

7. Equations – Solve for x

- 7.1. $3x - 7 = 8$ (2) 7.2. $-\frac{x}{4} + 3 = 11$ (2)
7.3. $\frac{x+2}{4} - \frac{x-6}{3} = 3$ (4) 7.4. $2 \times 3^{x+2} = 1458$ (3)
7.5. $2x = -\frac{x^2}{4} - 3$ (4) [15]

8. Exponents

- 8.1. $(x^5 \times x^3)^3$ (2) 8.2. $\sqrt[3]{216x^9}$ (2)
8.3. $\frac{15x^4y^{-3}z^0}{7xy^2z^4} \div \frac{25x^2y^3}{14z^5y^{-1}}$ (5)
8.4. It is 778 million Kilometres from the Earth to the planet Jupiter.
Express this distance in metres in scientific notation. (2) [11]

Section C

Data Handling

This is a table of the rainfall in Durban over the past 11 months;

Jan	Feb	Mar	Apr	May	Jun	Jul	Aug	Sep	Oct	Nov
125	110	110	73	59	28	39	21	52	65	77

- 9.1. Arrange the data in ascending order and determine the mean, median, mode and range for this data set. (7)
9.2. Draw a bar graph of this data on the graph paper provided. (5)
9.3. How much rain will need to fall in December if Durban is to achieve it's historic annual average of 980mm p.a. Do you think this is likely to happen? Justify your answer. (2) [14]

Transformation

- 10.1. Plot the following points on a Cartesian Plain provided, P(1;2), Q(3;5) and R(5;1). Join these points to form ΔPQR . (3)
- 10.2. Reflect ΔPQR in the 'x'-axis on the same number plane. (3)
- 10.3. Rotate ΔPQR through 90° in an anti-clockwise direction. (3)
- 10.4. On the same number plane, Translate ΔPQR left by 6 units and down 7 units. Number your transformations. (3)
- [12]

Probability

11. A deck of playing cards has 4 suits of 13 cards each. Diamonds and hearts are red, while clubs and spades are black cards.
- 11.1. What is the probability of drawing a red card at random from the pack? (1)
- 11.2. What is the probability of drawing a club at random from the pack? (1)
- 11.3. What is the probability of drawing an ace at random from the pack? (1)
- 11.4. What is the probability of drawing a King and a Queen at random from the pack? (2) [5]

Section D

Surface Area & Volume

Use the appropriate formula to complete the following;

Volume(V) _(cube) = s^3 or e^3 $V_{(rect. prism)} = lbh$	Total Surface area (TSA) _(cube) = $6s^2$ or $6e^2$ $TSA_{(rect. prism)} = 2(l \times b) + 2(l \times h) + 2(b \times h)$ $= 2(l + b)h + 2lb$
$V_{(\Delta prism)} = \frac{1}{2}b \times h \times H$	$TSA_{(\Delta prism)} = 2(\frac{1}{2}b \times h) + (s_1 \times h) + (s_2 \times h) + (s_3 \times h)$ $= (s_1 + s_2 + s_3) \cdot Ht + 2(\frac{1}{2} \cdot b \cdot h)$
$V_{(cylinder)} = \pi r^2 \times h$	$TSA_{(cylinder)} = (2\pi r^2) + (2\pi r \times h)$

12.1. Study the diagrams below of two chocolate boxes. Complete the following calculations to see which holds the most chocolate?

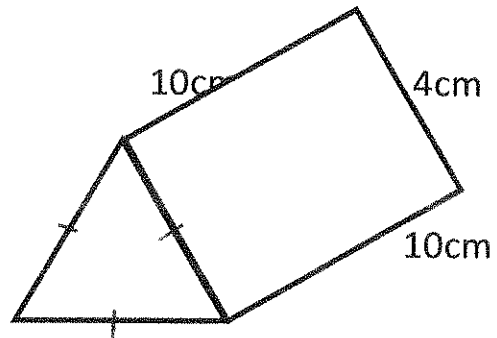
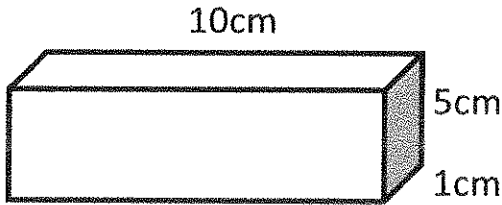

12.1.

- (i) Volume of the rectangular prism, 10cm by 5cm by 1cm. (3)
- (ii) The height of the triangle if the base is 4cm & (3)
- (iii) Volume of the Δ prism if the height is 10cm. (3)
- (iv) Which box holds the most Chocolate? (1)

12.2. How much cardboard is used to make the Toblerone chocolate box shown in 12.1. above, ignoring overlapping parts. (TSA) (3)

12.3. A cylindrical glass 15cm. tall with a radius of 2,5cm is filled to the top from a 330ml can of Coke. Calculate the volume of the glass to determine the amount of Coke left in the can correct to 1 decimal place. (4)

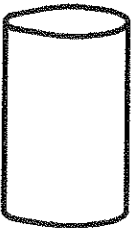

12.4. Given the diagram on the right with

$$AB = 2x + 5 \text{ \& } BC = x + 5$$

$$\text{And } PQ = x - 1 \text{ \& } PR = x - 1$$

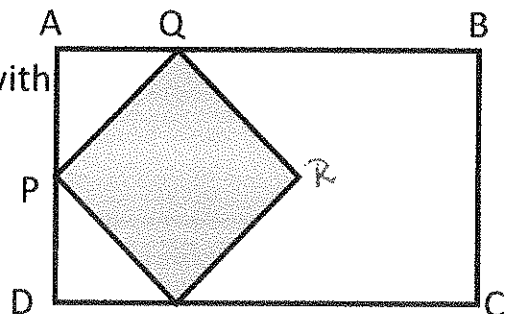

12.4.1. Find the area of rectangle ABCD (3)

12.4.2. Find the area of square PQRS (3)

12.4.3. Find the area of the unshaded region. (Give all answers for 12.4. in terms of x) (2) [25]

Section E – Answer on the diagram sheet in your answer book.

Geometry

- 13.1. Properties of a line. (5)
- 13.2. Properties of a triangle. (8)
- 13.3. Using Congruency to prove that the diagonals of a parallelogram bisect each other. (7)
- 13.4. Which of the following is not a congruency reference?
(SSS), (RHS), (AAA) & (ASA) (1)
- [21]

Graphs

- 14.1. Using your preferred method draw the graph of the function $f(x) = 3x - 2$, on the graph paper provided. (Label the coordinates of the points plotted) (5)
- 14.2. Draw a graph $g(x)$ perpendicular to the above function, $f(x)$, which passes through the origin. (2)
- 14.3. Give the equation of the function $g(x)$. (2)
- [30]

TOTAL 160

ANSWER BOOK

1	2	3	4	5	6	7	8	9	10	11	12	13	14	TOTAL

GRADE 9

MATHEMATICS

NAME: _____

DATE: _____

Question 9.2

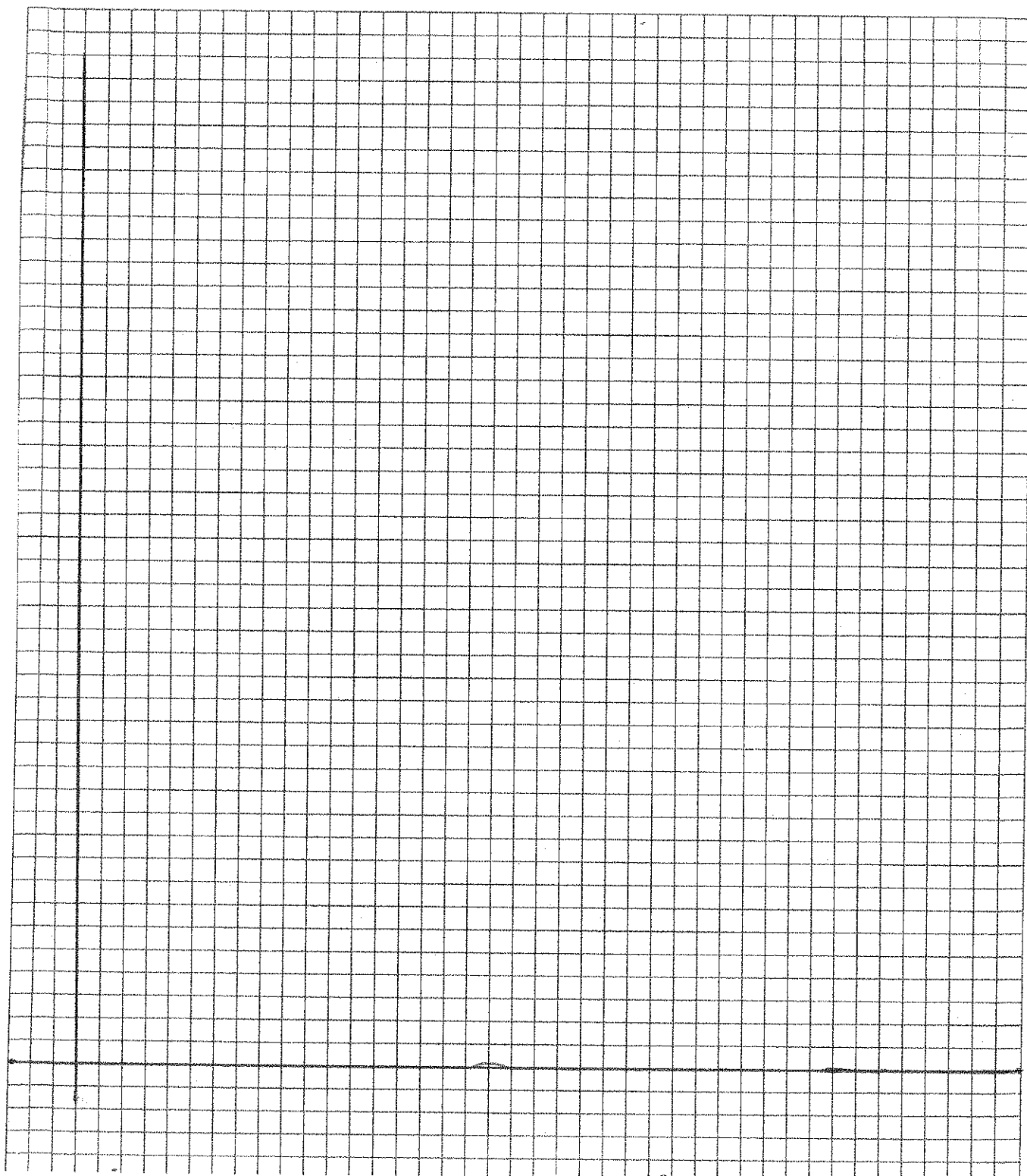

Question 10

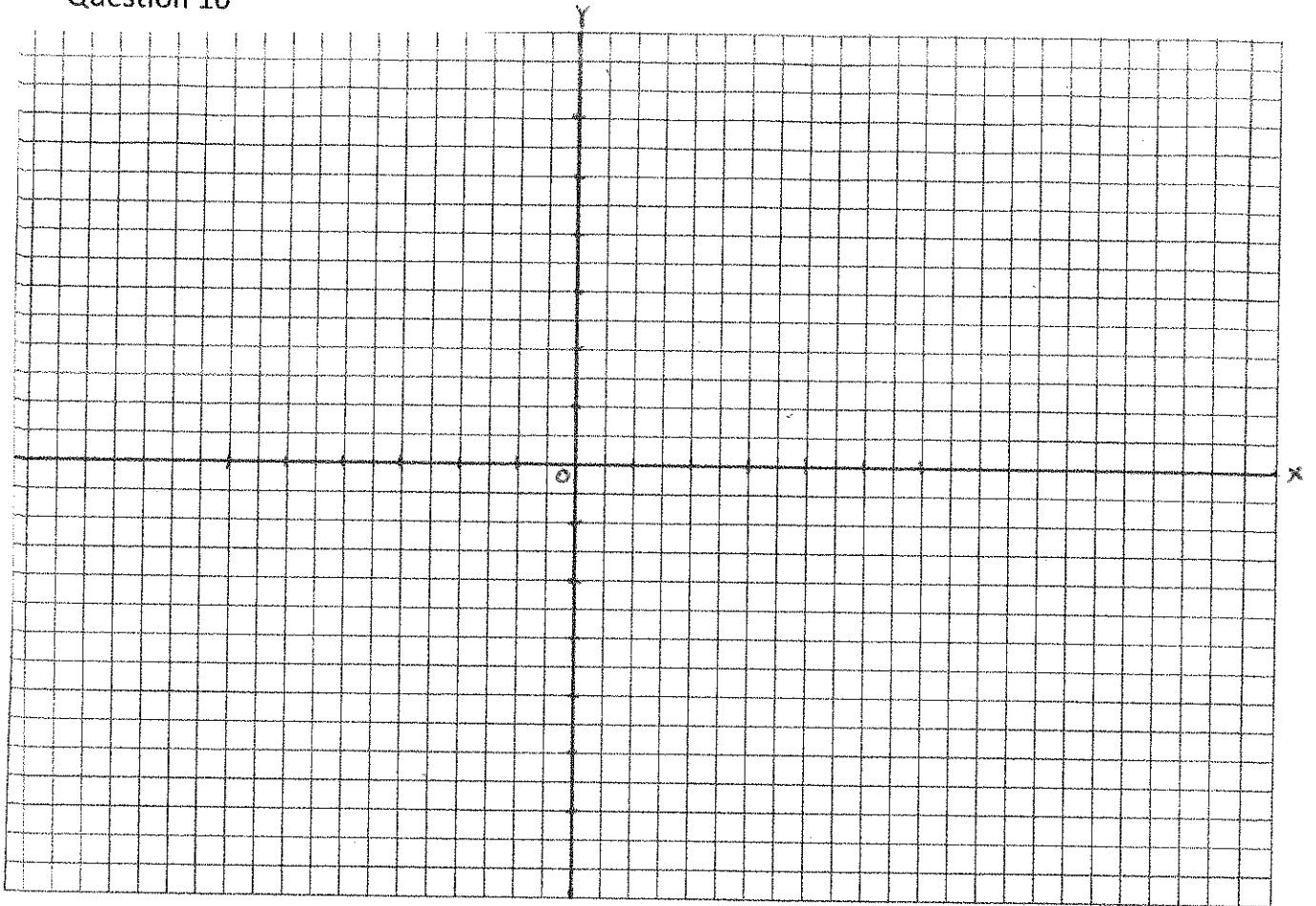

Question 14

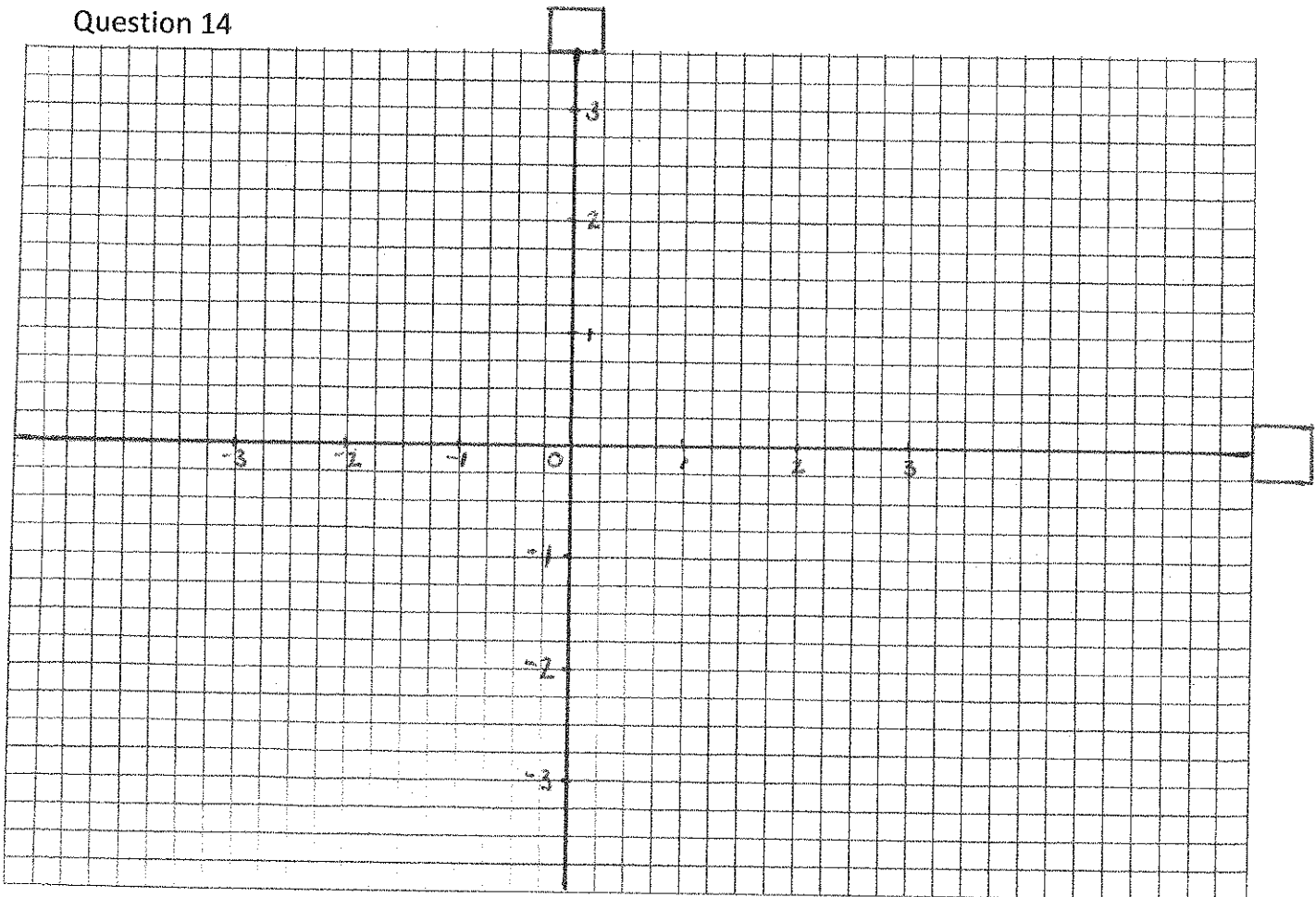

Section E – Answer Sheet

Name: _____

Complete the following statements, give references for each statement

13.1. Study the diagram on the right;

- $x = \underline{\hspace{2cm}}^\circ$ (_____)
- $x + 2y = \underline{\hspace{2cm}}^\circ$ (_____)
- $\therefore 2y = \underline{\hspace{2cm}}$
- $\therefore y = \underline{\hspace{2cm}}$

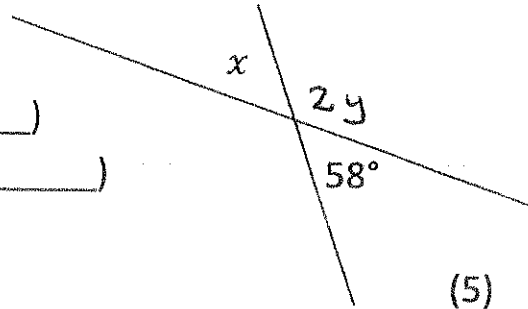

13.2.

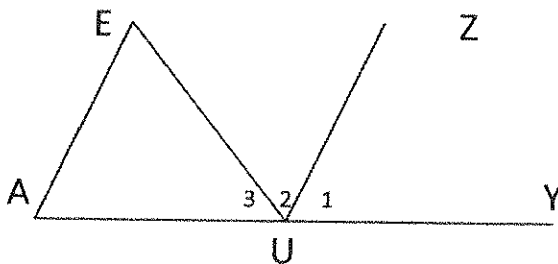

Given $AE \parallel UZ$

- $\hat{O}_1 = \underline{\hspace{2cm}}$ (_____ ; _____)
- $\hat{O}_2 = \underline{\hspace{2cm}}$ (_____ ; _____)
- $\hat{O}_1 + \hat{O}_2 = \hat{EUY} = \underline{\hspace{1cm}} + \underline{\hspace{1cm}}$ (ref; _____)
- $\hat{O}_1 + \hat{A} + \underline{\hspace{1cm}} = \underline{\hspace{1cm}}^\circ$ (ref; _____) (8)

13.3.

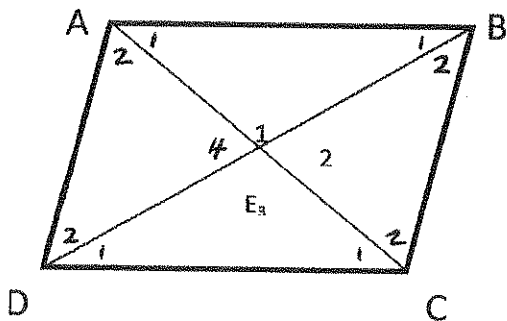

To Prove; $AE = \underline{\hspace{1cm}}$ & $BE = \underline{\hspace{1cm}}$

Proof; In $\triangle ABE$ and $\triangle \underline{\hspace{1cm}}$

- $AB = \underline{\hspace{1cm}}$ (_____)
- $\hat{A}_1 = \underline{\hspace{1cm}}$ (_____)
- $B_1 = \underline{\hspace{1cm}}$ (_____)
- $\therefore \triangle ABE \cong \triangle \underline{\hspace{1cm}}$ (_____) (7)

13.4. (_____) is not a Congruency proof reference. (1)