



HILLCREST HIGH SCHOOL

PHYSICAL SCIENCE

GRADE 10

PAPER 2- Chemistry



NOVEMBER 2014

TIME: 2 HRS

Total 140

## Instructions

1. Answer ALL the questions.
2. This question paper consists of TWO sections:
3. SECTION A (20)  
SECTION B (120)  
  
Answer SECTIONS A and B in the ANSWER BOOK.
4. Non-programmable calculators may be used.
5. Appropriate mathematical instruments may be used.
6. Number the answers correctly according to the numbering system used in this question paper.
7. Data sheets and a periodic table are attached for your use.
8. Give brief motivations, discussions, et cetera where required.
9. Numbers must be rounded off to two decimal places

## SECTION A

### QUESTION 1

Four options are provided as possible answers to the following questions. Each question has only ONE correct answer. Write only the letter (A – D) next to the question number (1.1– 1.10) in the ANSWER BOOK.

1.1 The diffusion rate for the three states of matter increases from ...

- A Solid → liquid → gas
- B Gas → solid → gas
- C Gas → liquid → solid
- D Liquid → gas → solid

1.2 The name of  $\text{Cr}(\text{HSO}_4)_3$  is?

- A Chromium trihydrogen sulphate.
- B Chromium (III) hydrogen sulphate.
- C Chromium sulphuric acid.
- D Chromium hydrogen sulphite.

1.3 Study the table below.

Which of the following elements is in a **liquid** state at room temperature?

Element	Melting point (°C)	Boiling point (°C)
Magnesium	650	1107
Oxygen	-218.4	-183
Carbon	3500	4827
Ethanol	-114	78.37
Sulphur	112.8	444.6

- A Oxygen
- B Magnesium
- C Sulphur and Magnesium
- D Ethanol

- 1.4 Which one of the following methods would you use to separate purple ink into its composition colours of red and blue?
- A Filtration
  - B Chromatography
  - C Manual separation
  - D Magnetic
- 1.5 In which one of the following compounds do BOTH the ions have the same electron configuration as Argon?
- A Calcium sulfide
  - B Magnesium oxide
  - C Sodium sulfide
  - D Calcium bromide
- 1.6 Which one of the following statements does not apply to a strong acid?
- A It has a high pH value.
  - B It undergoes complete ionisation.
  - C H<sub>2</sub>SO<sub>4</sub> is an example.
  - D It has a low pH value.
- 1.7 Consider the UNBALANCED equation below.
- $$\text{Al} + \text{O}_2 \rightarrow \text{Al}_2\text{O}_3$$
- The number of molecules of oxygen needed for 2 molecules of Al to react completely with oxygen is?
- A 1
  - B 1,5
  - C 2
  - D 3

1.8 The relative formula mass of  $(\text{COOH})_2 \cdot 10\text{H}_2\text{O}$  is ...

- A  $6,022 \times 10^{23} \text{ g} \cdot \text{mol}^{-1}$
- B  $126 \text{ g} \cdot \text{mol}^{-1}$
- C  $16200 \text{ g} \cdot \text{mol}^{-1}$
- D  $270 \text{ g} \cdot \text{mol}^{-1}$

1.9 A crystal that does not conduct electricity in the solid state but does when it is dissolved in distilled water is most likely to be.

- A Ionic.
- B Diatomic.
- C Monatomic.
- D Covalent.

1.10 Water can be classified as a(n)...

- A Element.
- B Compound.
- C Heterogeneous mixture.
- D Homologous mixture

[2 X 10 = 20]

SECTION A TOTAL = 20

**SECTION B**

**QUESTION 2**

Study the laboratory equipment shown below.

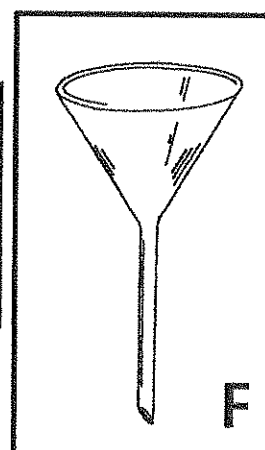
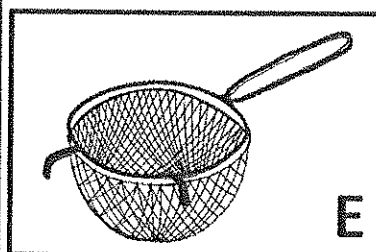
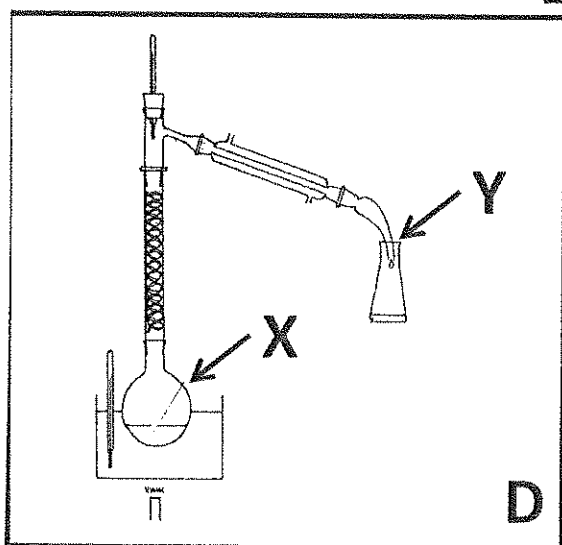
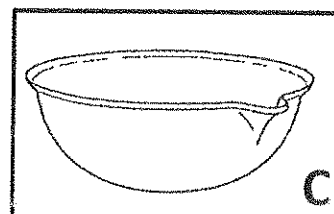
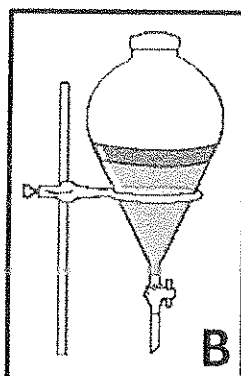
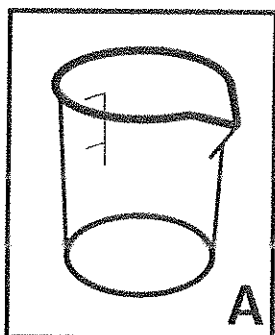

- 2.1 Give the names of the apparatus in diagrams A, C, E and F. (4)
- 2.2 Write the letter of the apparatus that one would use to separate
- 2.2.1 Two immiscible liquids.
  - 2.2.2 Alcohol from water.
  - 2.2.3 A solid from a solution.
  - 2.2.4 Oil from water. (4)

- 2.3 Consider apparatus D
- 2.3.1 Is this separation method a PHYSICAL or CHEMICAL process? (1)
  - 2.3.2 What property of the substances is used to separate them? (2)
  - 2.3.3 Is the mixture that is being separated HOMOGENEOUS or HETEROGENEOUS? (1)
  - 2.3.4 What phase change occurs at X? (1)
  - 2.3.5 What phase change occurs at Y? (1)
- [14]**

### QUESTION 3

- 3.1 Write down the chemical formulae for the following:
- 3.1.1 Calcium hydrogen carbonate. (1)
  - 3.1.2 Magnesium hydroxide. (1)
  - 3.1.3 Aluminium nitride. (1)
  - 3.1.4 Sodium oxide. (1)
- 3.2 Write down the name of the following formulae:
- 3.2.1  $\text{IF}_5$  (1)
  - 3.2.2  $\text{KMnO}_4$  (1)
  - 3.2.3  $\text{FeBr}_2$  (1)
  - 3.2.4  $\text{Li}_2\text{SO}_3$  (1)
- 3.3 What is the household (common) name for magnesium hydroxide? (1)
- 3.4 What is the chemical name for pool acid? (1)
- 3.5 Write down the name of the group of metals to which copper belongs. (1)
- [11]**

#### QUESTION 4

4.1 Consider the following electron-dot formulae for elements X and Y.

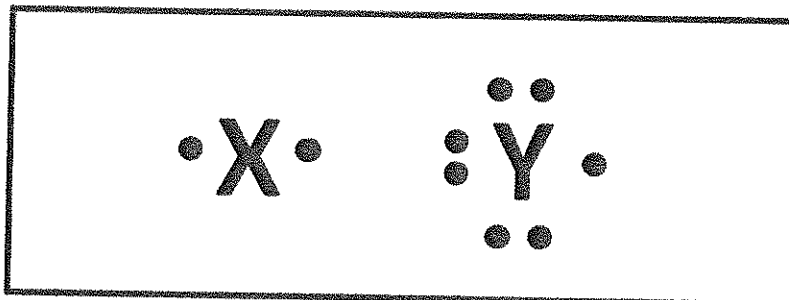

- 4.1.1 Will the compound that forms (when X and Y bond) be IONIC, COVALENT or METALLIC? (1)
- 4.1.2 Give a reason for your answer in QUESTION 4.1.1. (2)
- 4.1.3 Write down the formula for the compound formed by the combination of X and Y. (in the form of X and Y) (2)
- 4.1.4 Draw the Lewis diagram of the compound when X and Y react. (2)
- 4.2 Chlorine occurs in two isotopic forms  $^{35}\text{Cl}$  and  $^{37}\text{Cl}$ . The two isotopes are both suffocating but they are both important in our daily lives. The natural abundance of the isotopes is 75,53% for  $^{35}\text{Cl}$  and 24,47% for  $^{37}\text{Cl}$ .
- 4.2.1 Define the term ISOTOPE. (2)
- 4.2.2 Use a calculation to determine the number of neutrons in the isotope  $^{37}\text{Cl}$ . (2)
- 4.2.3 Use a calculation to show the relative atomic mass of chlorine is  $35,5 \text{ g}\cdot\text{mol}^{-1}$ . (3)
- 4.2.4 What precautions would you take when doing experiments with chlorine in a school laboratory? (1)

[15]

### QUESTION 5

- 5.1 Consider the first three elements of group II; namely Be, Mg and Ca.
- 5.1.1 Define the term ELECTRONEGATIVITY. (2)
- 5.1.2 Arrange the above mentioned elements in order of increasing electronegativity. (3)
- 5.1.3 Give a reason for your answer in QUESTION 5.1.2. (2)
- 5.1.4 Give the BALANCED CHEMICAL EQUATION for the reaction between beryllium and oxygen to produce the metal oxide.(in symbol form) (3)
- 5.2 Consider the first 4 elements in group VII; namely F, Cl, Br and I.
- 5.2.1 Arrange the above mentioned elements in decreasing order of atomic radius size. (4)
- 5.2.2 Discuss one reason for your answer in QUESTION 5.2.1 (1)
- 5.2.3 Give the common name for the elements in group VII. (1)
- 5.2.4 Give the **FORMULA** for the hydrogen halide that forms between hydrogen and bromine. (1)
- 5.2.5 Give the BALANCED CHEMICAL EQUATION for the reaction between potassium and iodine.(In symbol form) (3)

[20]

**QUESTION 6**

The states of matter are solid, liquid and gas. The diagram below shows how the molecules are arranged in these three states.

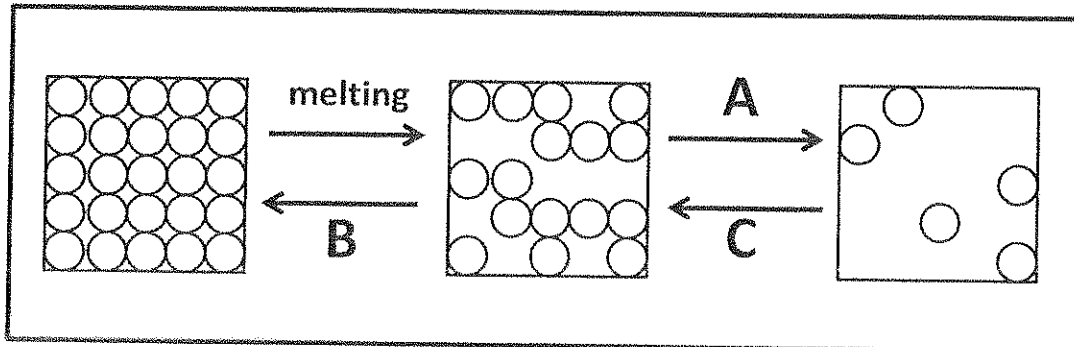

6.1 Write down the names of the processes that are represented by the following labels:

6.1.1 A (1)

6.1.2 B (1)

6.1.3 C (1)

6.2 Which of these processes (A, B or C) is endothermic? (1)

6.3 Give a reason for your answer in QUESTION 6.2. (1)

6.4 A substance is heated at a constant rate. The graph of its temperature against time is shown below.

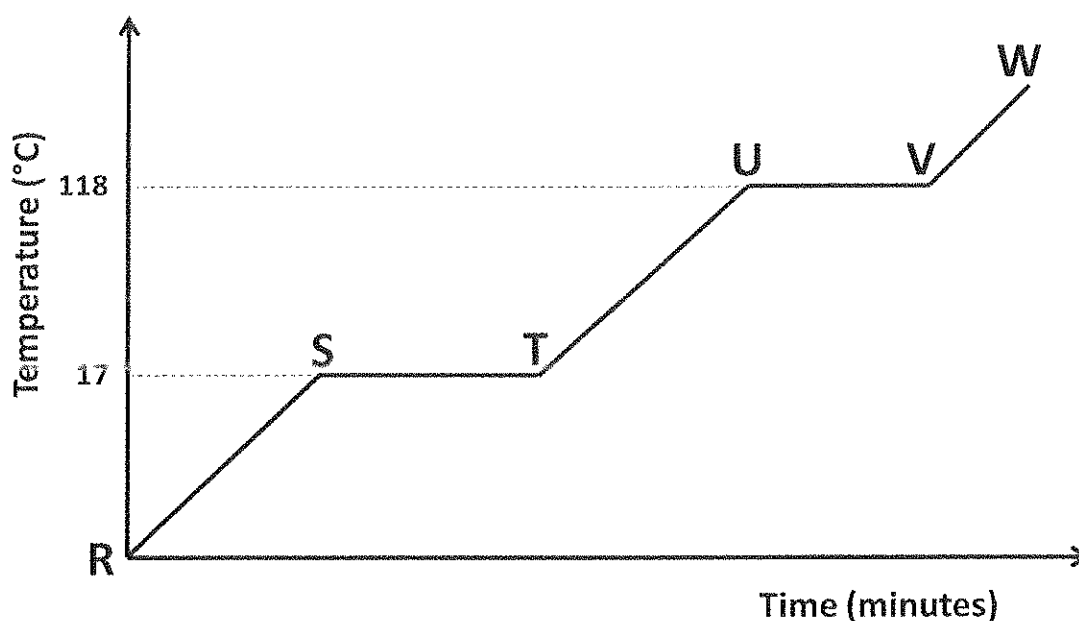

- 6.41 Write the TWO sections on the graph at which TWO phases of the substance exist at the same time. (2)
- 6.4.2 What is the melting point of the substance? (1)
- 6.4.3 What is the boiling point of the substance? (1)
- 6.4.4 What phase is represented by section V-W? (1)

[10]

### QUESTION 7

- 7.1 The gas ethene is analysed and found to contain 85,72% carbon and 14,28% hydrogen. Calculate the EMPIRICAL formula of ethene. (7)
- 7.2 A calcium chloride hydrate ( $\text{CaCl}_2 \cdot x\text{H}_2\text{O}$ ) has a mass of 4,72 g. After heating for several minutes the mass of the anhydrous salt is found to be 3,56 g. Use this information to determine the formula for the hydrate ( $\text{CaCl}_2 \cdot x\text{H}_2\text{O}$ ). (5)
- 7.3 If a 3,21 g sample of  $\text{BeC}_2\text{O}_4 \cdot 3\text{H}_2\text{O}_{(s)}$  is heated to  $220^\circ\text{C}$ , calculate:
- 7.3.1 The moles of  $\text{BeC}_2\text{O}_4 \cdot 3\text{H}_2\text{O}_{(s)}$  formed. (3)
- 7.3.2 Calculate the number of atoms found in the 3,21 g sample. (4)

[19]

### QUESTION 8

Hydrogen peroxide is a chemical compound with the formula  $\text{H}_2\text{O}_2$ . In its pure form it is a colourless liquid and is used as a bleaching agent and disinfectant. Hydrogen peroxide is thermodynamically unstable and decomposes to form water and oxygen.

Below is a graph that shows the decomposition of hydrogen peroxide.

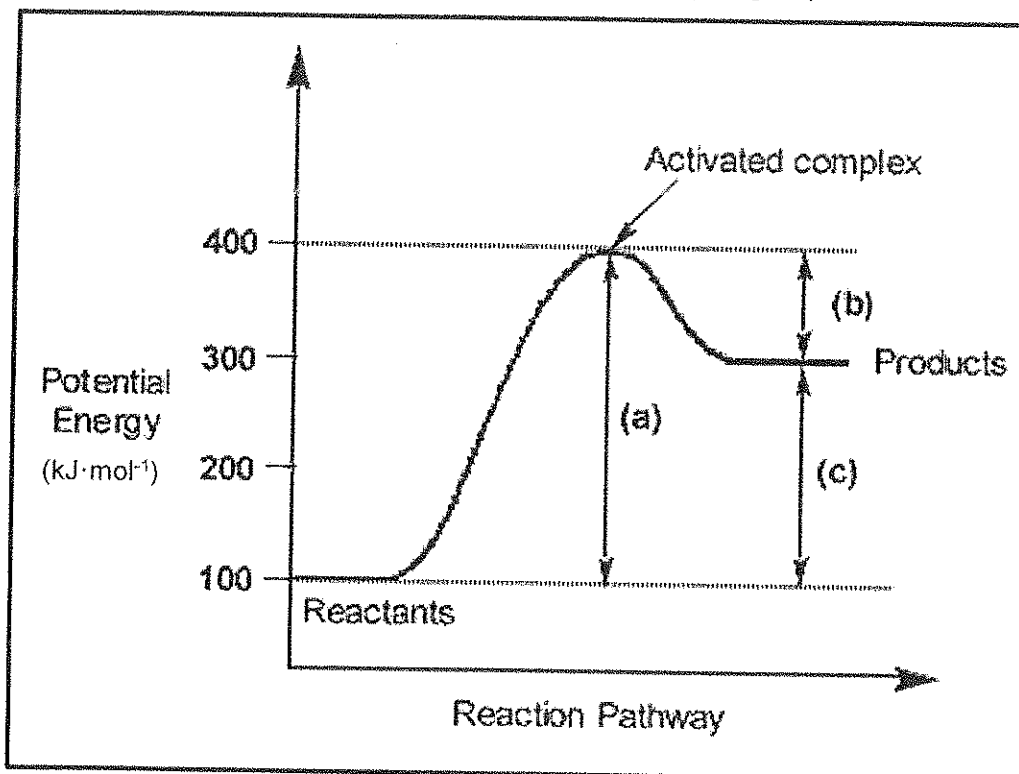

- 8.1 Is this decomposition reaction of hydrogen peroxide endothermic or exothermic? (1)
- 8.2 Calculate the enthalpy change of this decomposition reaction. (3)
- 8.3 Calculate the activation energy of this decomposition reaction. (1)
- 8.4 What is the energy of the products? (1)
- 8.5 Write the balanced chemical equation of this decomposition reaction of hydrogen peroxide. (3)
- [9]

### QUESTION 9

Sulphuric acid (used for production of fertilizers) is added to ammonium hydroxide (a weak base).

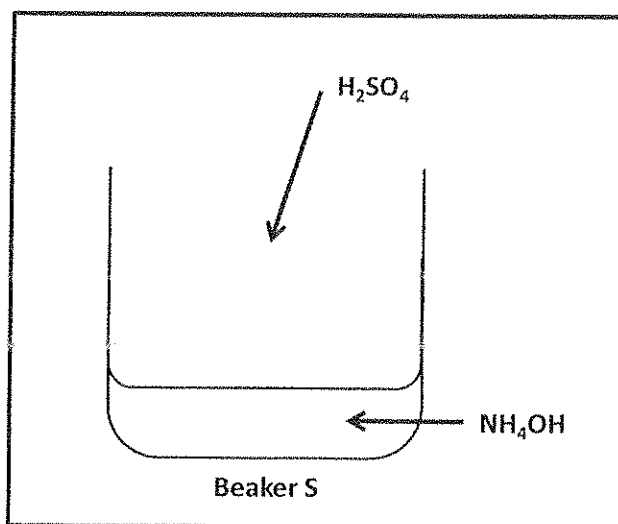

9.1 List three properties of a base. (3)

9.2 State whether the following statement is TRUE or FALSE:

**"An acid is a proton-donor"** (1)

9.3 Give the conjugated base of sulphuric acid (H<sub>2</sub>SO<sub>4</sub>). (1)

9.4 **COMPLETE AND BALANCE** the following chemical equation by rewriting the entire equation:



9.5 If Bromothymol blue is added to the NH<sub>4</sub>OH and then the H<sub>2</sub>SO<sub>4</sub> is added.

What colour change will be observed? (2)

**[10]**

### QUESTION 10

An investigation is carried out to determine the mass of sodium chloride and copper(II)sulphate that can dissolve in the same volume of water, at different temperatures. The results obtained are shown on the graph below.

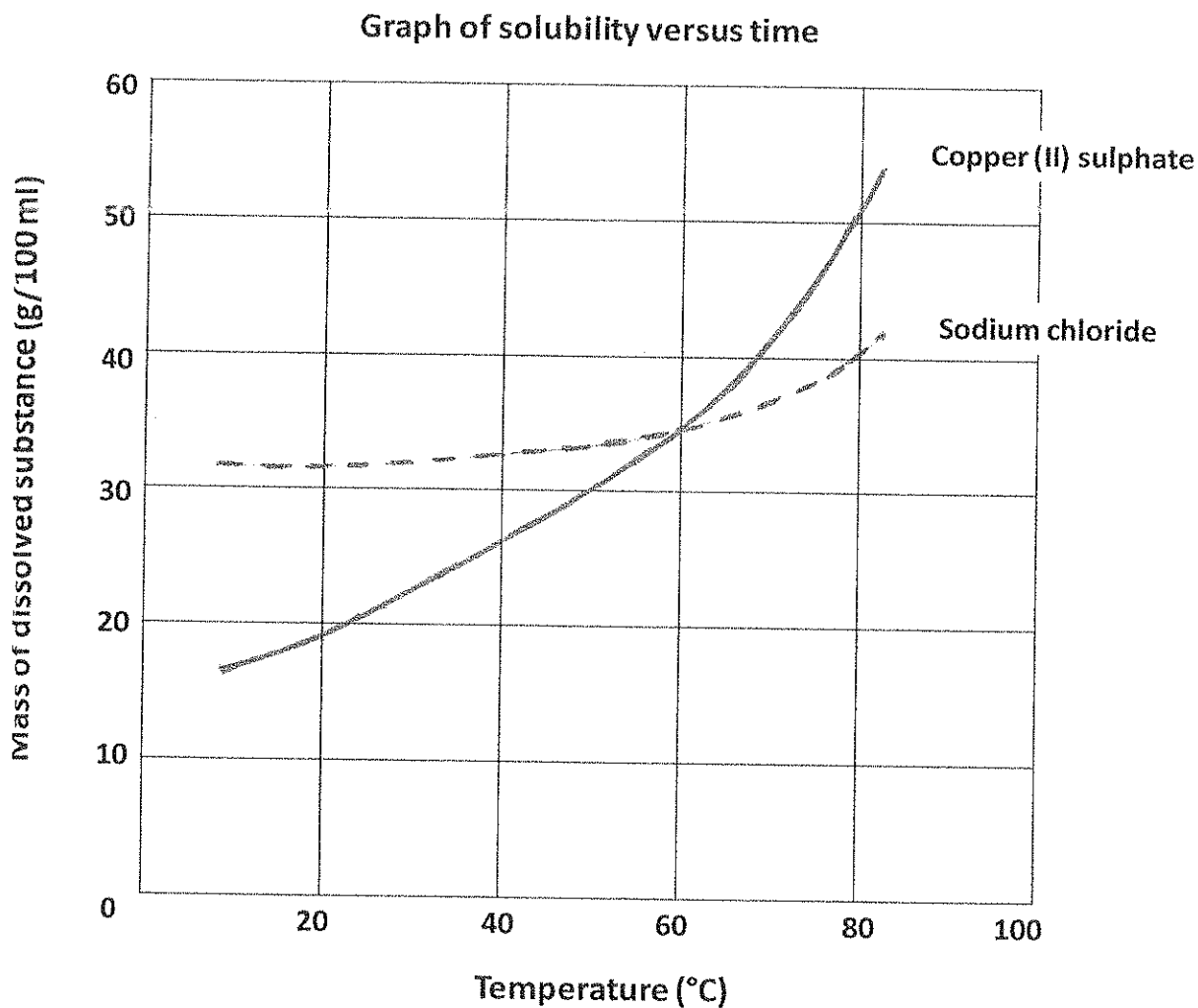

Use the graph to answer the following questions:

- 10.1 Name the independent variable. (1)
- 10.2 Name the dependent variable. (1)
- 10.3 Write down the factor that was kept constant during the investigation. (2)
- 10.4 Which ONE of the two substances is more soluble at room temperature (25°C)? (2)
- 10.5 Write down the temperature at which the solubility of these substances is equal. (2)

10) What mass of both salts is soluble at the temperature mentioned in QUESTION 10.5? (2)

10) What conclusion can you draw from the graph about the solubility of copper (II) sulphate? (2)

[12]

SECTION B TOTAL = 120

GRAND TOTAL = 140

## Formula sheet

Mass formula	$n = \frac{m}{M}$	
Particle formula	$n = \frac{No}{NA}$	$N_A = 6.02 \times 10^{23}$
Volume formula	$n = \frac{V}{V_o}$	$V_o = 22.4 \text{ dm}^3$
Concentration formula	$C = \frac{n}{V}$	
Neutrons	$n^0 = A - Z$	