

HILLCREST HIGH SCHOOL



NATURAL SCIENCE EXAM

GRADE 9

NOVEMBER 2017

TIME: 2 HRS

TOTAL : 120

EXAMINER: MRS SMITH

MODERATOR: MRS GROBLER

INSTRUCTIONS

1. This question paper consists of xxx pages and 3 sections:
SECTION A (30) SECTION B (40) SECTION C (50)
2. Answer all of the questions from SECTIONS A to C in the ANSWER BOOK provided.
3. Non-programmable calculators may be used.
4. Number the answers correctly according to the numbering system used in this question paper.
5. A formula sheet is provided for your use.
6. Give brief motivations, discussions, et cetera where required.
7. Calculations must be rounded off to two decimal places where appropriate.
8. **RULE OFF** after each question 1 – 14.

FORMULA SHEET

$$R = \frac{V}{I}$$

$$R_s = r_1 + r_2 + r_3 \dots\dots$$

$$\frac{1}{R_P} = \frac{1}{r_1} + \frac{1}{r_2} + \frac{1}{r_3} \dots\dots$$

$$F = mg$$

$$g_E = 9,8 \text{ m} \cdot \text{s}^{-2}$$

SECTION A

QUESTION 1: MULTIPLE CHOICE QUESTIONS

[10]

Four options are provided as possible answers to the following questions. Each question has only one correct answer. Write only the letter (A-D) next to the question number (1.1 - 1.10) in the answer book.

- 1.1 An example of a contact force is
- A. gravity
 - B. magnetism
 - C. friction
 - D. electrostatic
- 1.2 The more cells connected in parallel, the
- A. greater the current in the circuit
 - B. the greater the ammeter reading in the main circuit
 - C. the greater the voltmeter reading across the battery
 - D. the potential in the circuit remains the same.
- 1.3 The energy conversion that takes place in a coal-fired power station is
- A. gravitational to electrical
 - B. electrical to mechanical
 - C. chemical to mechanical
 - D. mechanical to electrical
- 1.4 An electrical cord has three insulated wires inside it. Which statement is correct?
- A. the brown wire is live and the blue wire is neutral
 - B. the green/yellow wire is neutral and the brown wire is live
 - C. the blue wire is live and the green/yellow wire is neutral
 - D. the brown wire is live and the blue wire is earth
- 1.5 Without using an electroscope, a reliable way of testing whether an object is positively charged is the following:
- A. a positive charge brought near to it, will be repelled
 - B. a negative charge brought near to it, will be attracted
 - C. a neutral body brought near to it, will be repelled
 - D. a neutral or negatively charged body positive brought near to it, will be repelled
- 1.6 Which of the following procedures is correct if there is a thunderstorm with lightning?
- A. You are able to continue taking a bath
 - B. You are safe if you are in a car
 - C. you can continue with your landline phone call
 - D. You can find shelter under a tree

- 1.7 One kWh (unit) of electricity cost 80 c. The cost of running an electric kettle (1200W) for 2,5 hours per week, for a month of four weeks is:
- A. 1,2 x 2,5 cents
 - B. 1,2 x 2,5 x 4 x 0,8 rands
 - C. 1,2 x 2,5 x 4 cents
 - D. $\frac{1,2 \times 2,5 \times 4}{0,8}$ cents
- 1.8 If all the conductors are made of copper wire, which one has the greatest resistance?
- A. long , thin , hot
 - B. short , thin , cool
 - C. long , hot , thick
 - D. short , cool , thick
- 1.9 Which of the following is NOT one of the Earth's atmospheric layers ?
- A. mesosphere
 - B. magnetosphere
 - C. stratosphere
 - D. troposphere
- 1.10 The sun is a
- A. supernova
 - B. red giant
 - C. white dwarf
 - D. middle aged star

QUESTION 2 : MATCHING COLUMNS

[10]

Match the statements in COLUMN A with the correct words in COLUMN B.

Write only the letters A – J next to the correct question number e.g 2.1 B

	COLUMN A		COLUMN B
2.1	type of metamorphic rock	A	nitrogen
2.2	an element found in the Earth's crust.	B	transformer
2.3	network of all the electrical transmission lines in the country	C	troposphere
2.4	a type of igneous rock	D	sandstone
2.5	a device that can change the voltage in cables	E	marble
2.6	rock formed when hot magma cools on the Earth's surface	F	ozone layer
2.7	a gas which makes up most of the atmosphere	G	national grid
2.8	section of the atmosphere made up of O ₃ molecules	H	oxygen
2.9	all weather occurs here	I	lava
2.10	type of sedimentary rock	J	granite

QUESTION 3 : TERMINOLOGY

[10]

Write down only the correct scientific term / words for the following descriptions.

- 3.1 Contact forces that a surface exerts on an object.
- 3.2 The type of force that exists when the North poles of two magnets are near each other.
- 3.3 Subatomic particles transferred during a lightning strike.
- 3.4 The component in an electrical circuit that measures the potential difference between two points in the circuit.
- 3.5 The rate at which electrical energy is transferred to an appliance.
- 3.6 The process during which rock is broken up naturally into smaller particles.
- 3.7 Water in any form that falls to the Earth's surface from clouds.
- 3.8 The process of birth, life and death of a star.
- 3.9 What a 'red giant' becomes once its fuel runs out.
- 3.10 The process by which stars produce their own light.

TOTAL SECTION A: [30]

SECTION B

INSTRUCTIONS

1. Leave one line between two sub question e.g between QUESTION 4.1 and QUESTION 4.2.
2. Carefully follow all instruction given when answering the questions.

QUESTION 4

[14]

4.1 Consider the instrument below .

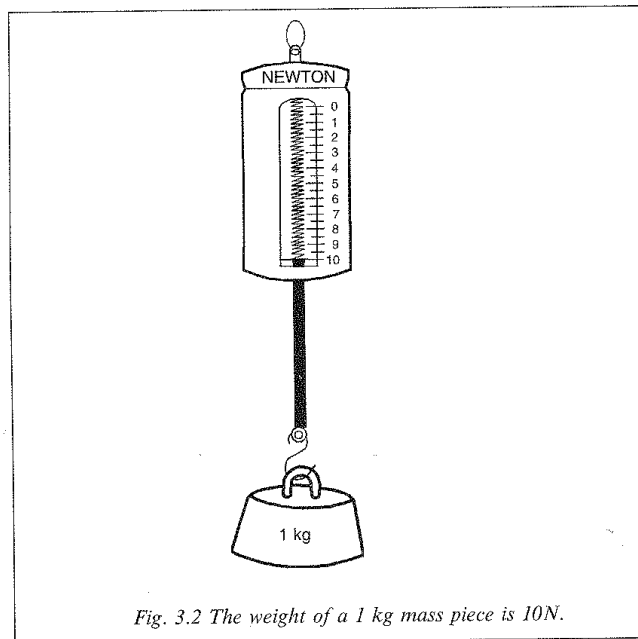

- 4.1.1 Name this instrument (1)
- 4.1.2 What is this instrument used to measure? (1)
- 4.1.3 What would the reading on this instrument be if a pencil case with a mass of 500g was hooked onto it? (4)
- 4.2 Four people struggle to push a car on a sandy road. They each exert a force of 200N and push the car in the direction of North as shown in the diagram below.



A frictional force exists between the road and the wheels, which makes it difficult for the men to move the car, and they only manage to create a resultant pushing force of 500N.

4.2.1 In which direction does the frictional force act? (1)

Calculate :

4.2.2 The size of the pushing force that these men apply to the car (2)

4.2.3 The size of the frictional force acting on the wheels of the car (2)

4.2.4 If the wheels of the car are old and worn, briefly explain how this would affect the resultant force acting on the car, and why this would happen. (3)

QUESTION 5

[10]

Study the circuit below and then answer the questions that follow

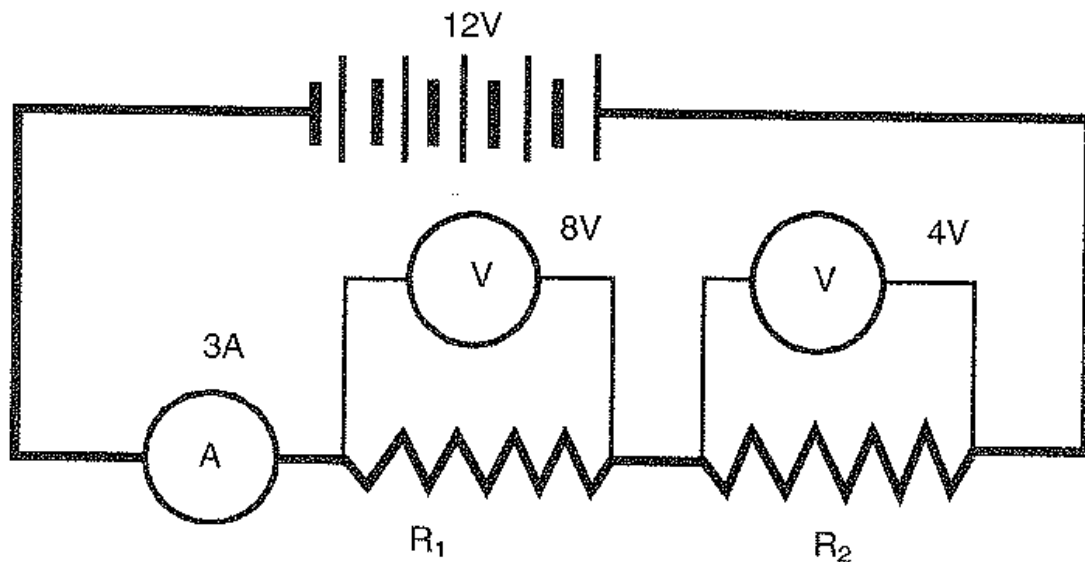

5.1 What is the emf of:

5.1.1 the battery? (1)

5.1.2 each cell (1)

5.2 Calculate

5.2.1 the total resistance of the circuit. (3)

5.2.2 the resistance of R2 (3)

5.3 What is the function of the ammeter in the circuit? (2)

QUESTION 6

[6]

- 6.1 Local government charges R1.50 per kWh for electrical energy in our homes. Calculate how much it costs to run a 2000W heater for 3 hours. (3)
- 6.2 Name three ways other than coal, in which electricity can be generated on a large scale. (3)

QUESTION 7

[10]

Study the graph and then answer the questions that follow in full sentences where required.

The graph below shows the amount of electricity that is used on one week day during summer and on one week day during winter in South Africa.

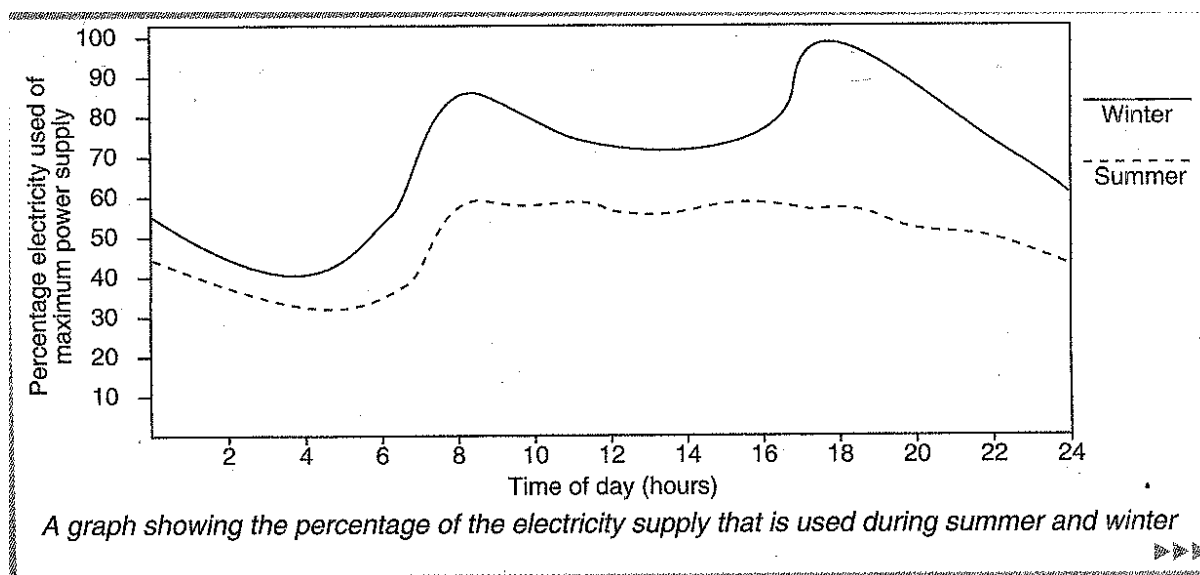

- 7.1 Why do you suppose more electricity used in winter than in summer? Give two reasons for your answer. (2)
- 7.2 At what time of the day is the most electricity used in winter? Explain why this is so. (2)
- 7.3 In your opinion, why is there a huge increase in electricity usage starting at 8h00 in both summer and winter than at any other time of the day? (2)
- 7.4 When is the least amount of electricity used in both summer and winter? Explain why this is so. (2)
- 7.5 Why do you think less electricity would be used between 11h00 and 16h00 in winter than at any other time of the day? (2)

TOTAL SECTION B: [40]

SECTION C

INSTRUCTIONS

1. Leave one line between two sub questions, e.g between QUESTION 7.1 and QUESTION 7.2.
2. Carefully follow all instruction given when answering the questions.

QUESTION 8

[6]

We burn coal to make steam to generate electricity in power stations.

Use the graph below to answer the questions that follow.

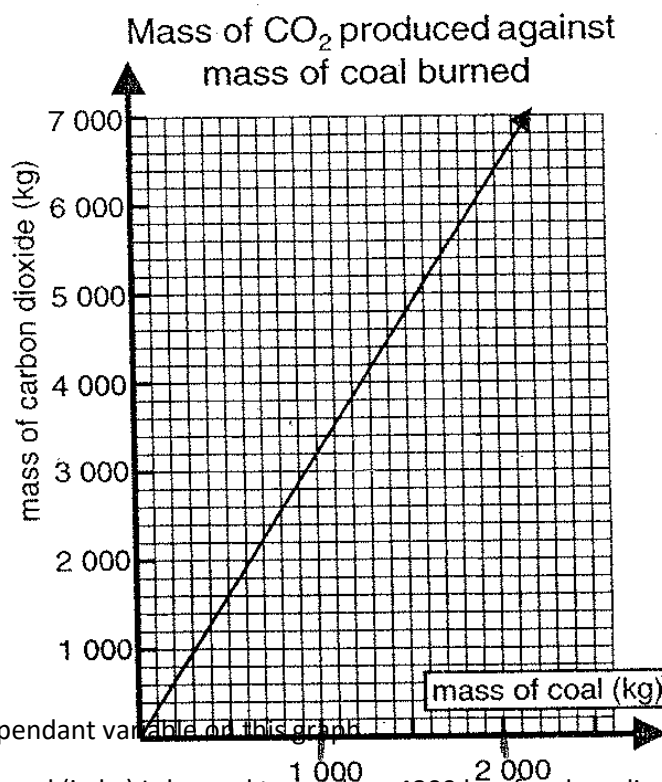

- 8.1 Name the dependant variable on this graph (1)
- 8.2 What mass of coal (in kg) is burned to produce 4800 kg of carbon dioxide (1)
- 8.3 What type of proportion exists between the dependent and the independent variable on this graph? (1)
- 8.4 Based on the information provided by the graph predict the mass of carbon dioxide produced if 4000 kg of coal is burned. Show your calculations. (3)

QUESTION 9

[10]

Burning coal releases greenhouse gases into the atmosphere. These greenhouse gases cause global warming.

The following bar graph displays information about an investigation between the sources and amounts of greenhouse gases on Earth.

Refer to the bar graph and answer the questions that follow.

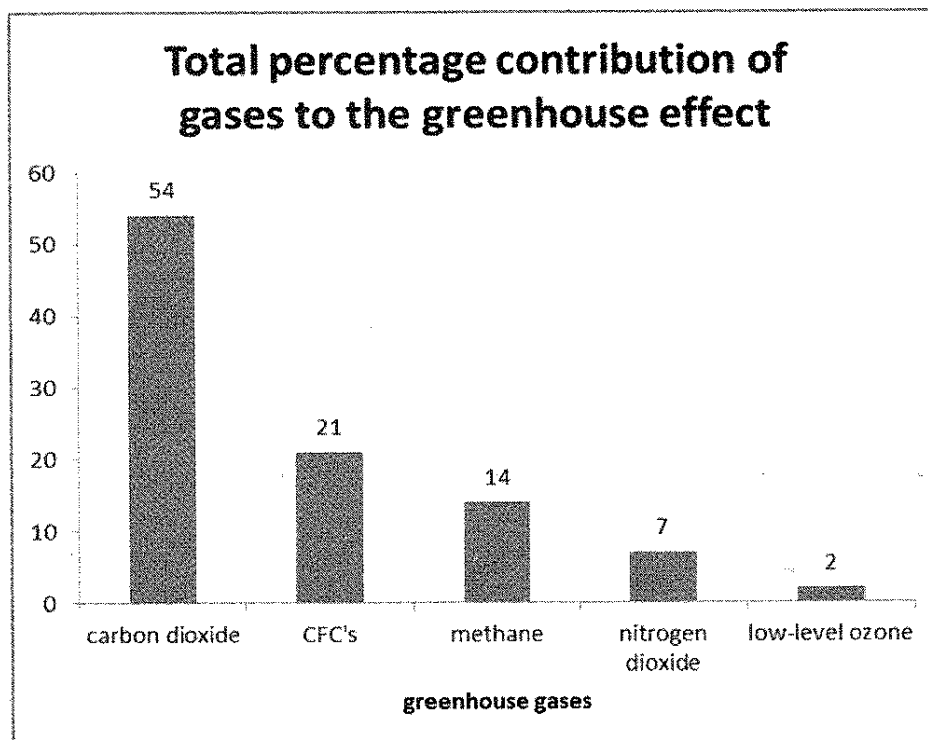

- 9.1 Suggest a suitable title for the y axis. (1)
- 9.2 A greenhouse gas that has been left off the graph is water vapour.
Calculate the percentage contribution of water vapour to the greenhouse effect from the data provided. Show all working. (2)
- 9.3 Discuss any two negative effects that Global warming has on the biosphere.
(Do not exceed 8 lines in your answer.) (4)
- 9.4 Identify a gas produced by
- 9.4.1 the excessive use of fertilizer (1)
- 9.4.2 the decomposition of organic matter. (1)
- 9.4.3 the cellular respiration of animals and plants. (1)

QUESTION 10

[12]

Read the passage below and then answer the questions that follow:

A major global environmental threat is unfolding, according to a group of the world's leading scientists, with the discovery that the Earth's upper atmosphere is cooling at a rate of 1 °C every year. The revelation, which is having an effect of "shrinking" the planet's atmosphere, could cause the disruption of the balance on Earth.

The rate of cooling has also alarmed experts who have determined that the mesosphere above the Earth has cooled by as much as 30 °C. Scientists warn that a rapid thinning of the ozone layer is occurring as a result, leading to a second major ozone hole. The cooling of the mesosphere and stratosphere is a direct result of global warming.

The other effect that is already starting to occur is the upper layers of the atmosphere descending further and further towards Earth.

While the greenhouse effect is warming the planet close to the surface – up to 15 km – this has been found to have an opposite effect on the upper levels of the atmosphere.

Heat radiating off the Earth is trapped in the lower level troposphere due to the accumulation of greenhouse gases such as carbon dioxide. This has resulted in the upper layers being starved of heat. Scientist predict that the accelerated greenhouse effect will continue to make the atmosphere smaller.

(Adapted from Science Tracks 8, 2004)

- 10.1 In which layer of the atmosphere is the ozone layer found? (1)
- 10.2 What function does the ozone layer serve? (1)
- 10.3 At approximately what altitude above Earth does space begin? (1)
- 10.4 In the article, what is 'unfolding" according to the world's leading scientist? (1)
- 10.5 What have scientist discovered is actually happening to the Earth's upper atmosphere? (1)
- 10.6 What effect will this have on the Earth's atmosphere in general? (1)
- 10.7 By how much has the mesosphere cooled in the last 30 years? (1)
- 10.8 What is happening to the ozone layer as a result of 10.7 above? (1)
- 10.9 The cooling of the mesosphere and stratosphere is a direct result of what environmental threat mentioned in the article? (1)
- 10.10 Which layer of the atmosphere has actually warmed up due the environmental threat mentioned in 10.9 above (1)
- 10.11 Explain how it is possible that this layering 10.10 becomes warmer. (2)

QUESTION 11

[10]

11.1.1 Identify the type of mining illustrated below.

(1)

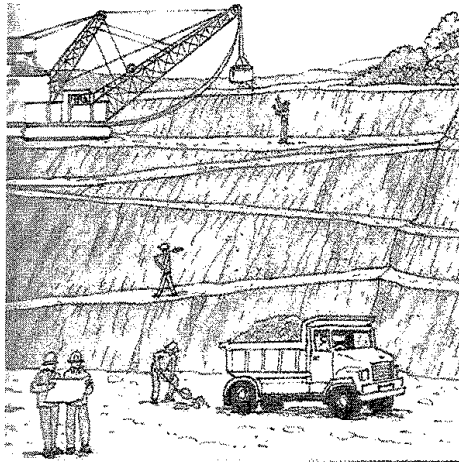

11.1.2 Identify the type of mining illustrated below.

(1)

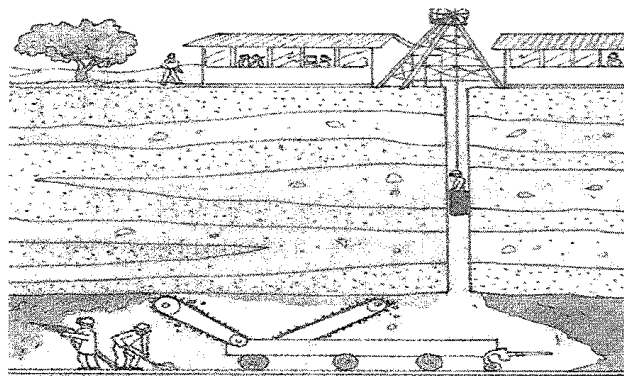

11.1.3 Which of these methods above is used to mine coal in South Africa?

(1)

11.2 Discuss two ways in which mining has a negative environmental impact.
(Do not exceed 8 lines in your answer.)

(4)

11.3 List three reasons how South Africa's mining industry has had benefits for the country. (3)

QUESTION 13

[6]

Some igneous rocks have small crystals and some have large crystals

13.1 Give an example of an igneous rock with large crystals.

(1)

13.2 Briefly explain how the rock in 13.1 forms.

(3)

13.4 Explain briefly how sedimentary shale becomes slate.

(2)

QUESTION 14

[6]

- 14.1 By what process do stars produce their own light? (2)
- 14.2 Briefly describe the process in 14.1 above (3)
- 14.3 What determines the colour of a star? (1)

TOTAL SECTION C : [50]

GRAND TOTAL : [120]