



# basic education

Department:  
Basic Education  
**REPUBLIC OF SOUTH AFRICA**

## **NATIONAL SENIOR CERTIFICATE**

**GRADE 11**

**PHYSICAL SCIENCES: PHYSICS (P1)**

**NOVEMBER 2018**

**MARKS: 150**

**TIME: 3 hours**

**This question paper consists of 15 pages and 2 data sheets.**



**INSTRUCTIONS AND INFORMATION**

1. Write your name and class (e.g. 11A) in the appropriate spaces on the ANSWER BOOK.
2. This question paper consists of 12 questions. Answer ALL the questions in the ANSWER BOOK.
3. Start EACH question on a NEW page in the ANSWER BOOK.
4. Number the answers correctly according to the numbering system used in this question paper.
5. Leave ONE line between two subquestions, e.g. between QUESTION 2.1 and QUESTION 2.2.
6. You may use a non-programmable calculator.
7. You may use appropriate mathematical instruments.
8. You are advised to use the attached DATA SHEETS.
9. Show ALL formulae and substitutions in ALL calculations.
10. Round off your FINAL numerical answers to a minimum of TWO decimal places.
11. Give brief motivations, discussions, etc. where required.
12. Write neatly and legibly.



**QUESTION 1: MULTIPLE-CHOICE QUESTIONS**

Various options are provided as possible answers to the following questions. Choose the answer and write only the letter (A–D) next to the question numbers (1.1 to 1.10) in the ANSWER BOOK, e.g. 1.11 D.

- 1.1 Two forces,  $F_1$  and  $F_2$ , act on a point. If  $F_1$  and  $F_2$  act in the same direction the maximum resultant has a magnitude of 13 N. If forces  $F_1$  and  $F_2$  act in opposite directions the magnitude of the minimum resultant is 3 N. The magnitude of the two forces, in newton, is ...

- A 8 and 5.  
B 16 and 10.  
C 3 and 10.  
D 10 and 7.

(2)

- 1.2 A free-moving block slides down an inclined plane at a **CONSTANT VELOCITY**. This means that the ...

- A frictional force acting on the block is zero.  
B net force acting on the block is in the direction down the slope of the plane.  
C net force acting on the block is zero.  
D component of weight parallel to the plane is greater than the frictional force.

(2)

- 1.3 A trolley is pushed along a horizontal surface with a force of 150 N at an angle of  $45^\circ$  to the horizontal. The trolley experiences a constant frictional force of 60 N.

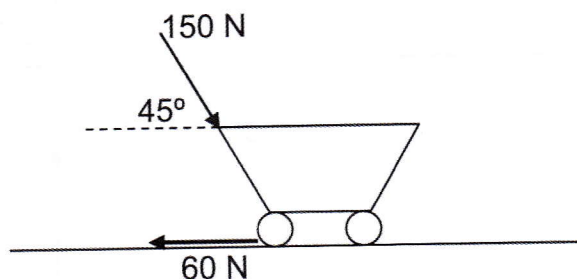

The **NET FORCE** acting on the trolley:

- (i) Causes the trolley to accelerate horizontally  
(ii) Is equal to the applied force  
(iii) Is horizontally forward

Which of the statements above are **CORRECT**?

- A (i) and (ii)  
B (ii) and (iii)  
C (i) and (iii)  
D (i), (ii) and (iii)



- 1.4 A man in a lift is moving upwards at a **CONSTANT SPEED**. The weight of the man is **W**. According to Newton's Third Law, the reaction force of the weight **W** is the force of ...
- A the floor on the man.
  - B Earth on the man.
  - C the man on the floor.
  - D the man on Earth. (2)
- 1.5 The optical density of a medium ...
- A will be high if the refraction of light is less.
  - B is a measure of the refracting power of the medium.
  - C is less when light bends towards the normal when entering the medium.
  - D will be high if light moves faster through the medium. (2)
- 1.6 In which **ONE** of the graphs below will the gradient represent the refractive index of a material when light passes from the air through the material?

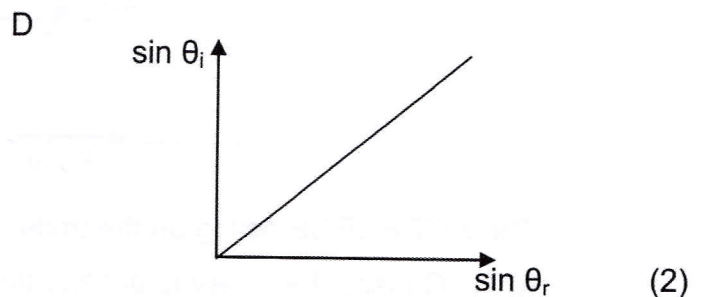
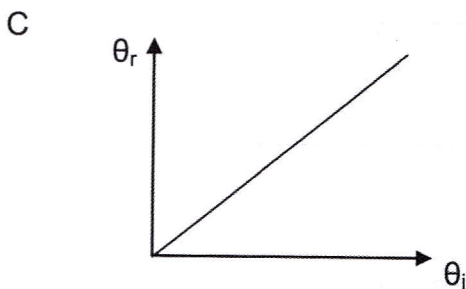
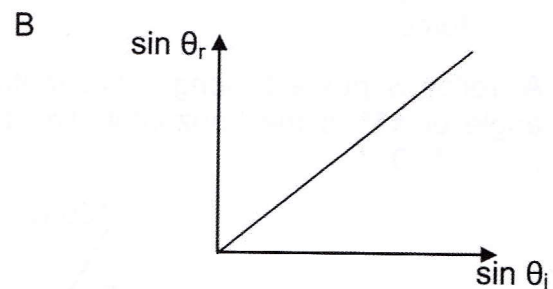
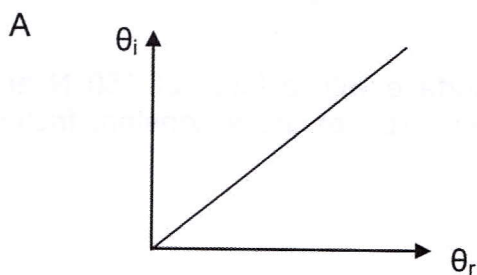

1.7 Every point on a wave front acts as a point source of spherical, secondary waves that move forward at the same speed as the wave. This statement represents ...

- A Snell's law.
- B Huygens' principle.
- C refraction.
- D the law of reflection.

(2)

1.8 Three charges of magnitudes  $+2q$ ,  $+2q$  and  $-2q$  are shown in the sketch below.

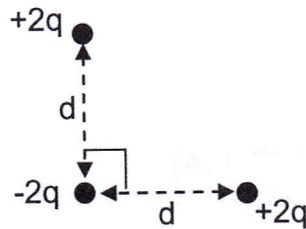

Which arrow CORRECTLY indicates the direction of the NET FORCE acting on the  $-2q$  charge?

- A
- B
- C
- D

(2)

1.9 Which ONE of the sketches below represents the CORRECT magnetic field pattern around a straight current-carrying conductor?

- A
- B
- C
- D

(2)

**QUESTION 3 (Start on a new page.)**

A box, with a mass of 45 kg, is pulled with a force of 90 N at an angle of  $50^\circ$  to the horizontal. The box moves at a **CONSTANT VELOCITY**.

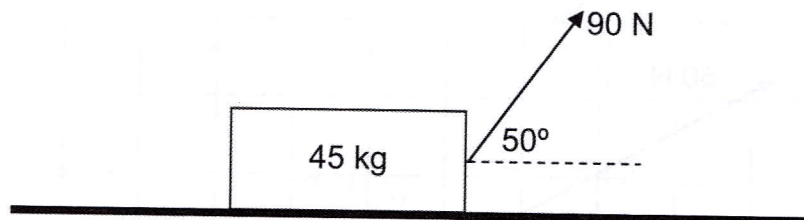

- 3.1 Define the term *kinetic frictional force*. (2)
- 3.2 State *Newton's First Law of Motion* in words. (2)
- 3.3 Calculate the magnitude of the horizontal component of the applied force. (2)
- 3.4 Calculate the magnitude of the normal force. (4)
- 3.5 Calculate the coefficient of kinetic friction. (4)
- 3.6 Will the coefficient of kinetic friction change if the angle of the applied force is decreased? Write only YES or NO and give a reason. (2)

**[16]**

**QUESTION 4 (Start on a new page.)**

Learners investigate the relationship between the mass of an object and the acceleration it experiences when a constant net force is applied on the object. They use their results to draw the graph below.

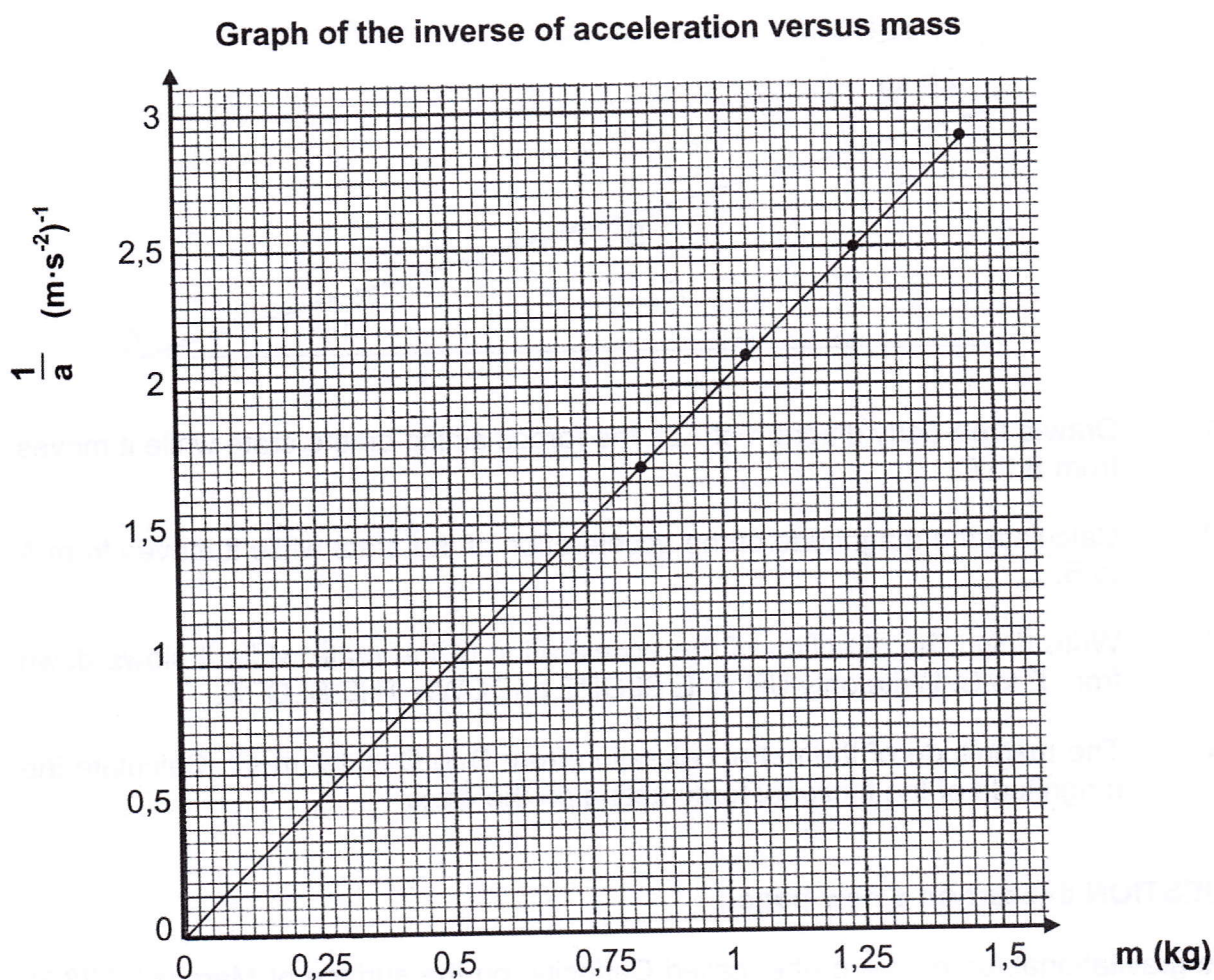

- 4.1 State *Newton's Second Law of Motion* in words. (2)
- 4.2 Calculate the gradient of the graph. (3)
- 4.3 Hence, determine the net force applied on the object during the experiment. (2)
- 4.4 Write down a conclusion for this experiment. (2)

**[9]**

**QUESTION 5 (Start on a new page.)**

A crate, with a mass of 25 kg, slides down a plane which is inclined at  $15^\circ$  to the horizontal. During the first part of the motion, from A to B, there is no friction between the crate and the plane, but part BC has a rough surface.

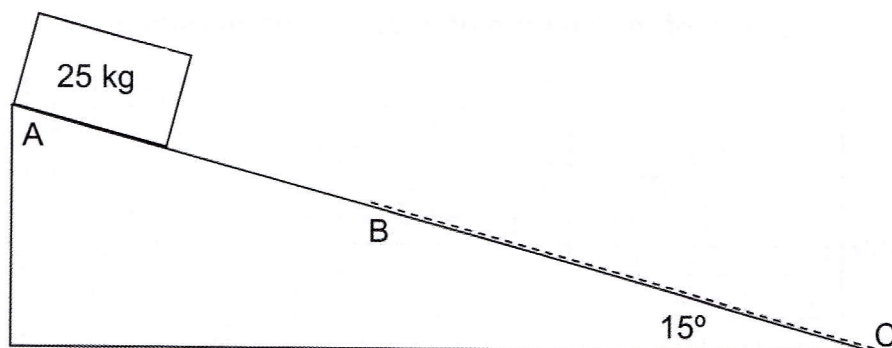

- 5.1 Draw a free-body diagram of ALL the forces acting on the crate while it moves from B to C. (3)
- 5.2 Calculate the magnitude of the acceleration of the crate while it moves from A to B. (4)
- 5.3 Write down the direction of the acceleration of the crate while it slows down from B to C. Write only UP THE SLOPE or DOWN THE SLOPE. (1)
- 5.4 The magnitude of the net acceleration from B to C is  $1,2 \text{ m}\cdot\text{s}^{-2}$ . Calculate the magnitude of the frictional force acting on the crate. (4)
- [12]**

**QUESTION 6 (Start on a new page.)**

The gravitational force on a probe, called Curiosity, on the surface of Mars is 3 338 N. The radius of Mars is 3 390 km and the mass of the planet is  $6,39 \times 10^{23} \text{ kg}$ .

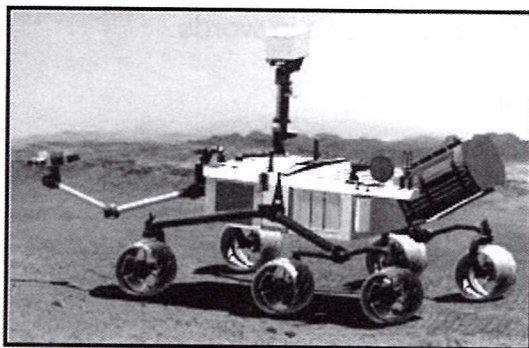

- 6.1 State *Newton's Law of Universal Gravitation* in words. (2)
- 6.2 Calculate the mass of the probe. (4)
- 6.3 Calculate the weight of the probe on Earth. (2)
- [8]**



**QUESTION 7 (Start on a new page.)**

A glass prism is placed at the bottom of a container filled with water. A light ray passes from the air through the water into the glass prism. The light ray changes direction every time it passes into a new medium.

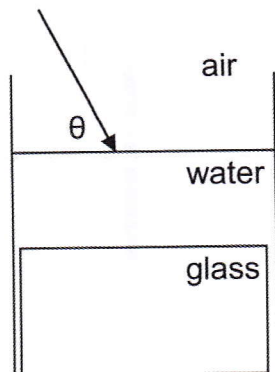

- 7.1 Name the phenomenon described by the underlined words above. (1)
- 7.2 If the refractive index of water and air is 1,33 and 1 respectively, calculate the angle  $\theta$  between the light ray and the SURFACE OF THE WATER if the angle of refraction in the water is  $40^\circ$ . (4)
- 7.3 The angle of refraction in the glass is  $35^\circ$ . Calculate the refractive index of glass. (3)
- 7.4 Draw the sketch below and complete the diagram of the path of the light ray from the air to the water to the glass. Show ALL the values of the angles of incidence, angles of refraction and normal in EACH medium.

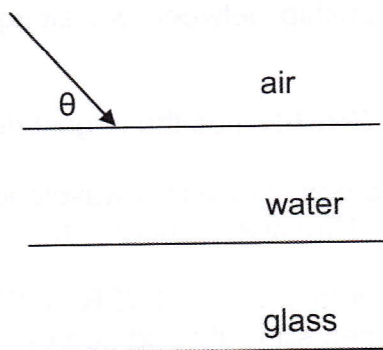

- 7.5 Calculate the speed of light through the glass prism if the refractive index of glass is 1,5. (3)
- 7.6 Is it possible that total internal reflection of the light ray can occur in the above situation? Write only YES or NO. (1)

**[17]**

**QUESTION 8 (Start on a new page.)**

An experiment is performed to investigate the effect of wavelength on the degree of diffraction. Monochromatic light shines through a slit with a width of 0,002 mm and the pattern produced is shown on a screen.

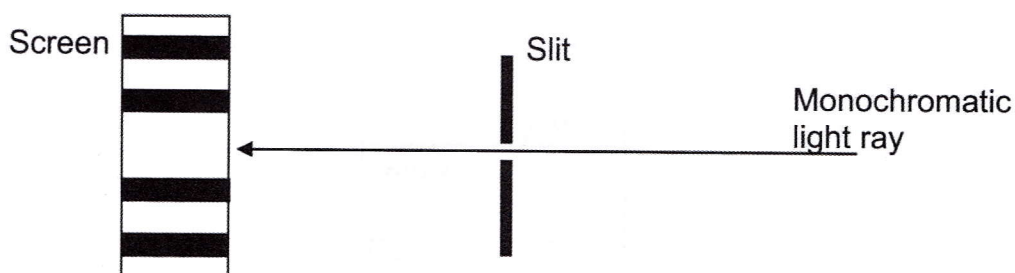

8.1 Define the term *diffraction*. (2)

8.2 Write an investigative question for this experiment. (2)

The degree of diffraction is recorded for different colours of monochromatic light and the results are shown on the graph below.

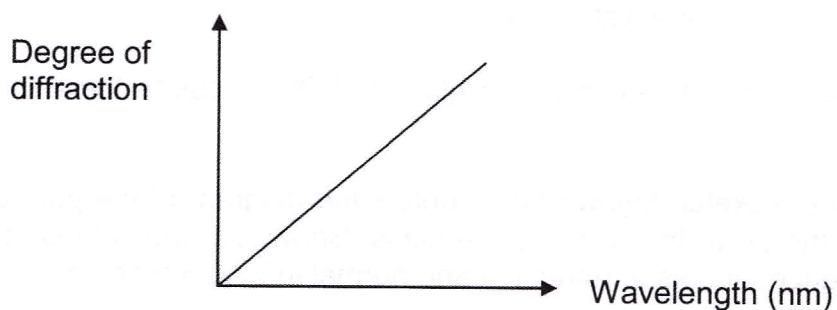

8.3 Write the mathematical relationship between wavelength and the degree of diffraction. (2)

8.4 Which colour of light, RED or GREEN, has the largest degree of diffraction? (1)

The experiment is repeated with only green light with a wavelength of 560 nm, but the slit width is changed and the degree of diffraction is recorded.

8.5 Copy the set of axes below into your ANSWER BOOK and draw a graph showing the relationship between slit width and degree of diffraction. (2)

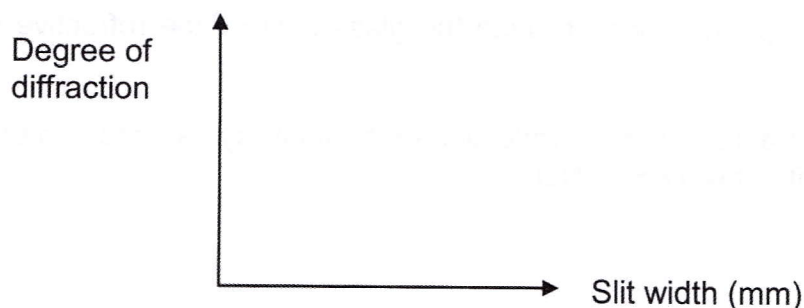

(2)  
[9]



**QUESTION 9 (Start on a new page.)**

A small isolated sphere A, with a mass of 0,2 g, carrying a charge of  $+7 \times 10^{-9}$  C, is suspended from a horizontal surface by a string of negligible mass. A second sphere B, carrying a charge of  $-8 \times 10^{-9}$  C, on an isolated stand, attracts sphere A so that the string forms an angle of  $20^\circ$  to the vertical. The horizontal distance between the centres of the two spheres is 3 cm. Refer to the diagram below.

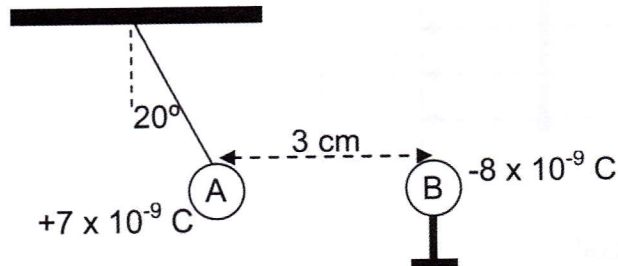

- 9.1 State *Coulomb's law* in words. (2)
- 9.2 Draw a VECTOR DIAGRAM of the forces acting on sphere A. Indicate at least ONE angle. (4)
- 9.3 Calculate the magnitude of the electrostatic force that sphere B exerts on sphere A. (4)
- 9.4 Calculate the magnitude of the tension force in the string. (3)
- [13]**

**QUESTION 10 (Start on a new page.)**

Two points, P and T, are situated 3 mm apart in the electric field of positive charge Q, as shown below.

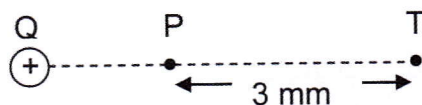

- 10.1 Draw the electric field pattern around charge Q. (2)

The magnitude of the electric field at point P is  $4 \times 10^6 \text{ N}\cdot\text{C}^{-1}$  and at point T the magnitude is  $2,5 \times 10^5 \text{ N}\cdot\text{C}^{-1}$ .

- 10.2 Calculate:
- 10.2.1 The ratio of the electric field at point P to the electric field at point T. Write the answer as  $E_P : E_T$ . (1)
- 10.2.2 The distance between charge Q and point P (4)
- 10.2.3 The magnitude of charge Q (2)
- [9]**

**QUESTION 11 (Start on a new page.)**

A SQUARE induction coil with a side length 3 cm and 400 windings, is placed perpendicularly in a uniform magnetic field and then rotated through an angle of  $45^\circ$  in 0,08 s.

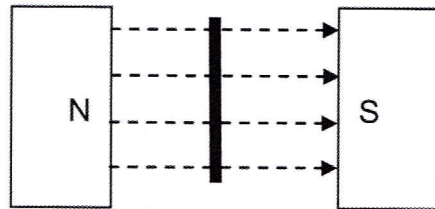

An emf of 7 V is induced in the coil.

- 11.1 State *Faraday's law of electromagnetic induction* in words. (2)
- 11.2 Calculate the change in the magnetic flux. (3)
- 11.3 Calculate the magnitude of the magnetic field. (4)

The coil is now rotated through an angle of  $45^\circ$  in 0,05 s.

- 11.4 How will the induced emf be affected? Write only INCREASE, DECREASE or STAY THE SAME. (1)
- 11.5 Explain the answer to QUESTION 11.4. (1)

The north pole of a bar magnet is pushed into a solenoid, as shown in the sketch below.

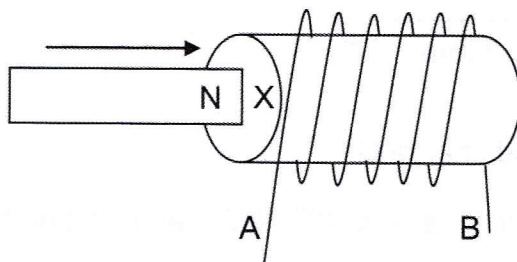

- 11.6 Which pole will be induced at point X? Write only NORTH or SOUTH. (1)
- 11.7 In which direction will the induced current flow? Write only FROM A TO B or FROM B TO A. (1)
- [13]**



**QUESTION 12 (Start on a new page.)**

Consider the circuit diagram below. The internal resistance of the battery and any resistance in the wires can be ignored.

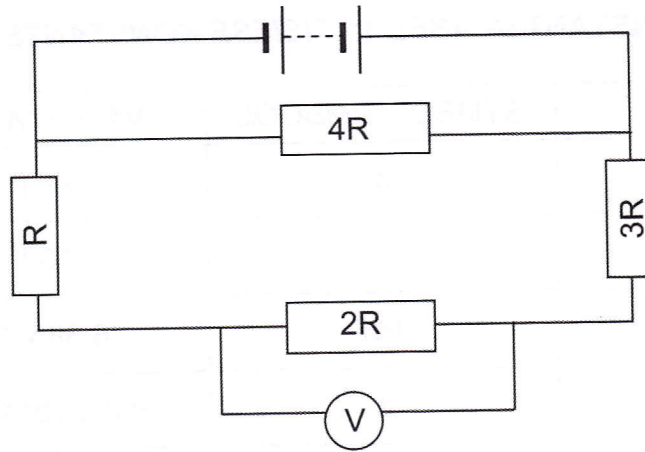

- 12.1 Calculate the value of resistor  $R$  if the total resistance of the circuit is  $4,8 \Omega$ . (3)
- 12.2 Calculate the reading on the voltmeter if the current through the  $4R$  resistor is  $1,8 \text{ A}$ . (5)
- 12.3 Calculate the energy converted in resistor  $4R$  in 2 minutes. (3)

The  $4R$  resistor is replaced with an ammeter.

- 12.4 How will the reading on the voltmeter be influenced? Write only INCREASE, DECREASE or STAY THE SAME. (1)
- 12.5 Explain the answer to QUESTION 12.4. (2)

**[14]**

**TOTAL: 150**



**DATA FOR PHYSICAL SCIENCES GRADE 11  
PAPER 1 (PHYSICS)**

**GEGEWENS VIR FISIESTE WETENSAPPE GRAAD 11  
VRAESTEL 1 (FISIKA)**

**TABLE 1: PHYSICAL CONSTANTS/TABEL 1: FISIESTE KONSTANTES**

NAME/NAAM	SYMBOL/SIMBOOL	VALUE/WAARDE
Acceleration due to gravity <i>Swaartekragversnelling</i>	g	9,8 m·s <sup>-2</sup>
Gravitational constant <i>Swaartekragkonstante</i>	G	6,67 x 10 <sup>-11</sup> N·m <sup>2</sup> ·kg <sup>-2</sup>
Radius of Earth <i>Radius van die Aarde</i>	R <sub>E</sub>	6,38 x 10 <sup>6</sup> m
Coulomb's constant <i>Coulomb se konstante</i>	k	9,0 x 10 <sup>9</sup> N·m <sup>2</sup> ·C <sup>-2</sup>
Speed of light in a vacuum <i>Spoe van lig in 'n vakuum</i>	c	3,0 x 10 <sup>8</sup> m·s <sup>-1</sup>
Charge on electron <i>Lading op elektron</i>	e	-1,6 x 10 <sup>-19</sup> C
Electron mass <i>Elektronmassa</i>	m <sub>e</sub>	9,11 x 10 <sup>-31</sup> kg
Mass of Earth <i>Massa van die Aarde</i>	M	5,98 x 10 <sup>24</sup> kg

**TABLE 2: FORMULAE/TABEL 2: FORMULES**

**MOTION/BEWEGING**

$v_f = v_i + a \Delta t$	$\Delta x = v_i \Delta t + \frac{1}{2} a \Delta t^2$
$v_f^2 = v_i^2 + 2a \Delta x$	$\Delta x = \left( \frac{v_f + v_i}{2} \right) \Delta t$

**FORCE/KRAG**

$F_{\text{net}} = ma$	$w = mg$
$F = \frac{Gm_1m_2}{r^2}$	$\mu_s = \frac{f_{s(\text{max/maks})}}{N}$
$\mu_k = \frac{f_k}{N}$	



**WAVES, SOUND AND LIGHT/GOLWE, KLANK EN LIG**

$v = f \lambda$	$T = \frac{1}{f}$
$n_i \sin \theta_i = n_r \sin \theta_r$	$n = \frac{c}{v}$

**ELECTROSTATICS/ELEKTROSTATIKA**

$F = \frac{kQ_1Q_2}{r^2}$ ( $k = 9,0 \times 10^9 \text{ N}\cdot\text{m}^2\cdot\text{C}^{-2}$ )	$E = \frac{F}{q}$
$E = \frac{kQ}{r^2}$ ( $k = 9,0 \times 10^9 \text{ N}\cdot\text{m}^2\cdot\text{C}^{-2}$ )	$n = \frac{Q}{e}$

**ELECTROMAGNETISM/ELEKTROMAGNETISME**

$\varepsilon = -N \frac{\Delta\Phi}{\Delta t}$	$\Phi = BA \cos \theta$
--	-------------------------

**ELECTRIC CIRCUITS/ELEKTRIESE STROOMBANE**

$I = \frac{Q}{\Delta t}$	$R = \frac{V}{I}$
$\frac{1}{R} = \frac{1}{r_1} + \frac{1}{r_2} + \frac{1}{r_3} + \dots$	$R = r_1 + r_2 + r_3 + \dots$
$W = Vq$	$P = \frac{W}{\Delta t}$
$W = VI \Delta t$	$P = VI$
$W = I^2 R \Delta t$	$P = I^2 R$
$W = \frac{V^2 \Delta t}{R}$	$P = \frac{V^2}{R}$



