



HILLCREST HIGH SCHOOL
PHYSICAL SCIENCE
GRADE 10
PAPER 1 - Physics



NOVEMBER 2021
TIME: 2 HRS

Total: 100

Instructions

1. Answer ALL the questions.
2. This question paper consists of TWO sections:
3. SECTION A (12)
SECTION B (88)

Answer SECTIONS A and B in the ANSWER BOOK.
4. Non-programmable calculators may be used.
5. Appropriate mathematical instruments may be used.
6. Number the answers correctly according to the numbering system used in this question paper.
7. Data sheets are attached for your use.
8. Give brief motivations, discussions, et cetera where required.
9. Numbers must be rounded off to **two decimal** places.

SECTION A

QUESTION 1: MULTIPLE-CHOICE QUESTIONS

Four options are provided as possible answers to the following questions. Each question has only ONE correct answer. Write only the letter (A – D) next to the question number (1.1 – 1.10) in the ANSWER BOOK.

- 1.1 If a 100 g ball is dropped from a 30m high building. What would the potential energy at a height of 10 m be equivalent to?
- A $E_{\text{mech}}(\text{top})$
 - B $E_k(10\text{m})$
 - C $E_{\text{mech}}(\text{top}) - E_k(10\text{m})$
 - D $E_p(\text{bottom})$
- 1.2 Delleshan stands at Ushaka pier and observes that 6 crests of a wave pass a fixed point every second. What is the period of the wave?
- A 0.17 s
 - B 6 s
 - C 0.2 s
 - D 5 s
- 1.3 The area under a velocity-time graph can be used to calculate the _____ of an object:
- A Acceleration
 - B Displacement
 - C Final velocity
 - D Time

1.4 Two pulses are travelling towards each other along a string, as shown in the diagram below.

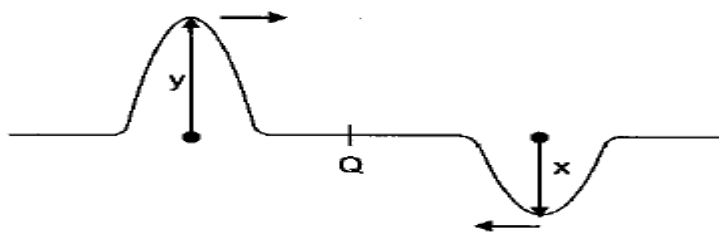

When the centres of the pulses meet at Q, the amplitude of the resultant pulse will be...

- A. $x + y$
- B. $2(x + y)$
- C. $2(y - x)$
- D. $y - x$

1.5 Consider the closed circuit represented below.

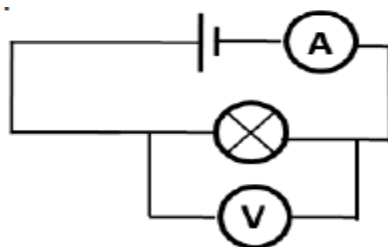

How will the ammeter and voltmeter readings change, if the bulb burns out?

	Ammeter reading...	Voltmeter reading...
A	Becomes zero	Does not change
B	Becomes zero	Increases
C	Does not change	Does not change
D	Increases	Becomes zero

1.6 A 200 g ball is dropped from a 50 m high building. At a height of 30 m the speed of the ball will be:

- A 39,2 m.s⁻¹
- B 19,8 m.s⁻¹
- C 392 m.s⁻¹
- D 98 m.s⁻¹

[2 X 6 = 12]

Question 2

The transverse wave below has a frequency of 1.50 Hz.

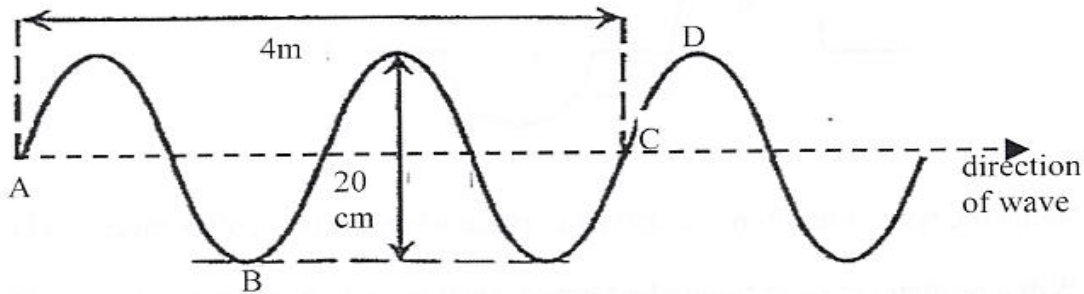

- 2.1 Define the term wavelength. (2)
- 2.2 Use the diagram to determine the value of the :
 - 2.2.1 Wavelength. (1)
 - 2.2.2 Amplitude. (1)
- 2.3 State ONE similarity between a particle at point B and a particle at point D. (1)
- 2.4 If point A is taken as the starting point of the wave then:
 - 2.4.1 How long will a particle take to move from point A to point D ? (3)
 - 2.4.2 Calculate the speed of the wave. (3)

[11]

Question 3

A geologist is surveying a remote valley. He finds a deep mineshaft filled with water. He places an echo-sounding device on the water surface to find the depth of the shaft. Sound waves are sent downwards from the transmitter, reflected off the bottom of the shaft, and picked up by the receiver placed next to the transmitter. The transmitter sends a sound wave and the receiver picks up the reflected wave 0.018 s later. The speed of the sound waves in water is 1500 m.s^{-1} .

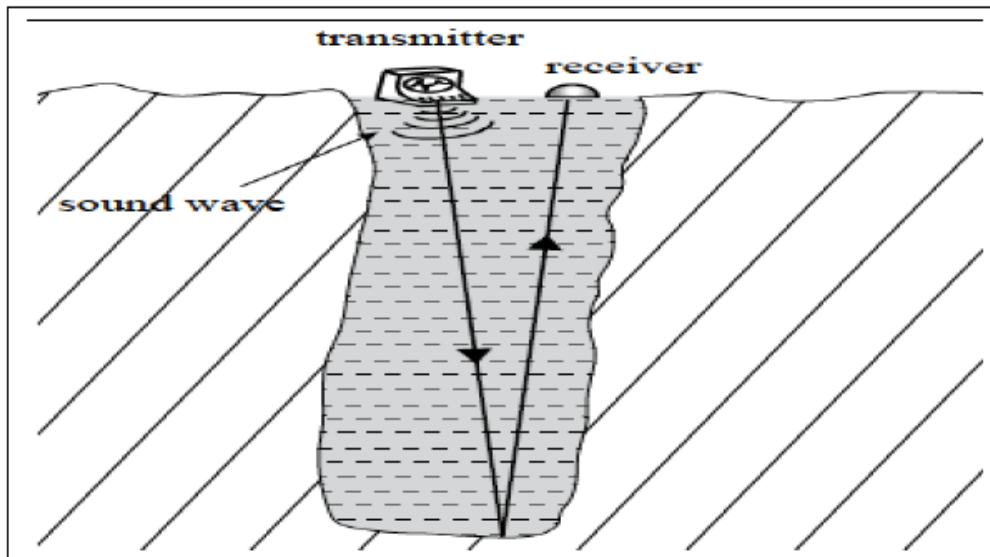

3.1 What type of a wave is a sound wave?

(1)

3.2 Calculate the depth of the mineshaft.

(5)

[6]

Question 4

Over 100 years ago scientists thought that there must be an invisible substance in space that enables light to travel from the sun to the earth. It has now been established that sunlight reaches the earth in the form of electromagnetic waves.

Below is a table of different radiations of the electromagnetic spectrum.

Type of Radiation	Wavelength (m)
Radio waves	6×10^2
Infrared	4×10^{-5}
Visible light	5×10^{-6}
Ultraviolet light	3×10^{-7}
X – rays	2×10^{-10}
Gamma rays	5×10^{-13}

- 4.1 How are electromagnetic waves generated? (1)
- 4.2 State ONE risk associated with overexposure to sunlight. (1)
- 4.3 From the table above name the type of electromagnetic radiation that:
- 4.3.1 Has the highest penetrating ability. (1)
- 4.3.2 Is used in television remote controls. (1)
- 4.4 If a photon of sunlight contains 6.63×10^{-19} J of energy determine which ONE of the radiations in the table above is mainly found in sunlight. Show all the necessary calculation in your answer. (5)
- [9]**

Question 5

5.1 Three metal spheres are placed on insulated stands and carry charges as shown below.

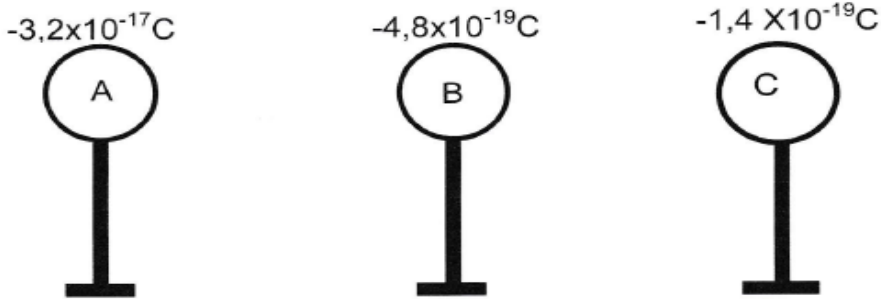

5.1.1 Determine the number of excess electrons found on sphere A. (3)

5.1.2 Is it possible for the charge indicated on sphere C to exist?

State YES or NO. Give a reason for the answer. (2)

5.1.3 Name the principle used to explain your answer to questions 5.1.2. (1)

5.2 Two metal spheres are placed on insulated stands as shown below.

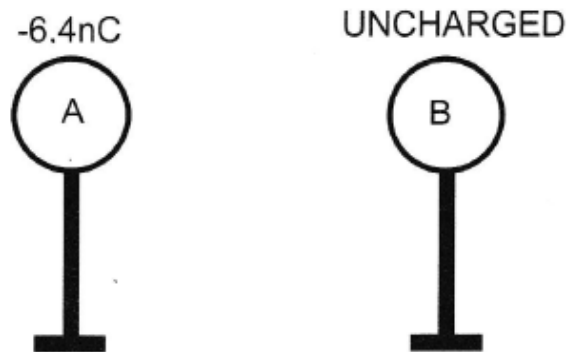

Sphere A carries a charge of -6.4 nC and sphere B is UNCHARGED.

5.2.1 What is meant by *sphere B is uncharged*? (2)

Sphere A is now brought CLOSE to sphere B. The spheres DO NOT touch.

5.2.2 Draw a sketch to show the charge distribution that takes place on sphere B. (2)

5.2.3 Name the phenomenon as described in question 5.2.2. (1)

The two spheres are now made to TOUCH each other, and they are then separated.

5.2.4 State the Law of Conservation of Charge (2)

5.2.5 Calculate the new charge on each sphere after touching. (3)

5.3 Refer to the six spheres A - F below. Sphere A is POSITIVELY charged. The charges on the other spheres are unknown.

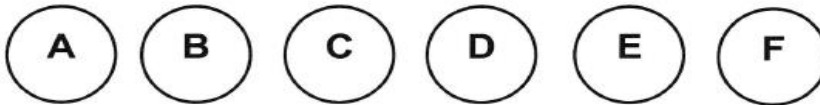

A learner wishes to determine the nature of the charges (positive, negative or neutral) on the other 5 spheres.

She makes the following observations:

- F attracts both A and B
- D repels C
- E attracts D but repels F
- C attracts B

Use the above information to determine the nature of the charges on spheres B, C, D, E and F. (5)

[21]

Question 6

In the circuit below the internal resistance of the 6 V battery is negligible. The resistance of the connecting wires is negligible. When switch **S** is closed, the current in the 6 Ω resistor is 0,6 A.

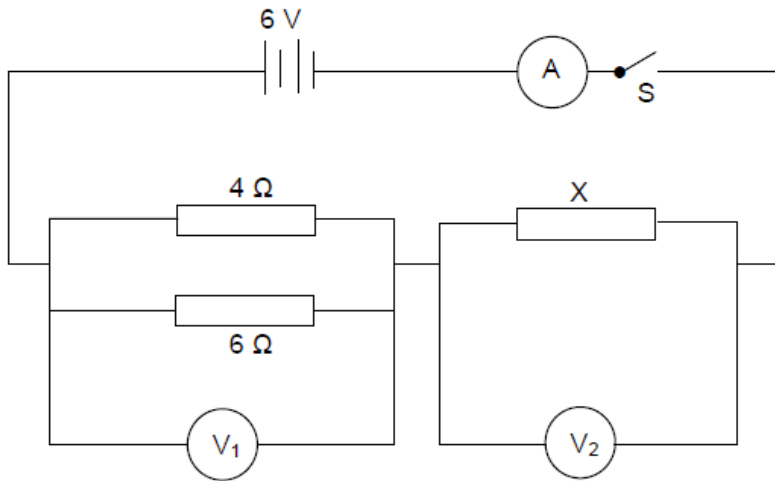

6.1 State Ohm's law in words. (2)

Calculate the:

6.2 Current passing through the 4 Ω resistor (4)

6.3 Total current in the circuit (2)

6.4 Resistance X (3)

The 4 Ω resistor gets hotter than the 6 Ω resistor after a while.

6.5 Explain this observation. (3)

[14]

Question 7

The velocity-time graph of an object is shown below. The object is initially moving in a **southerly** direction.

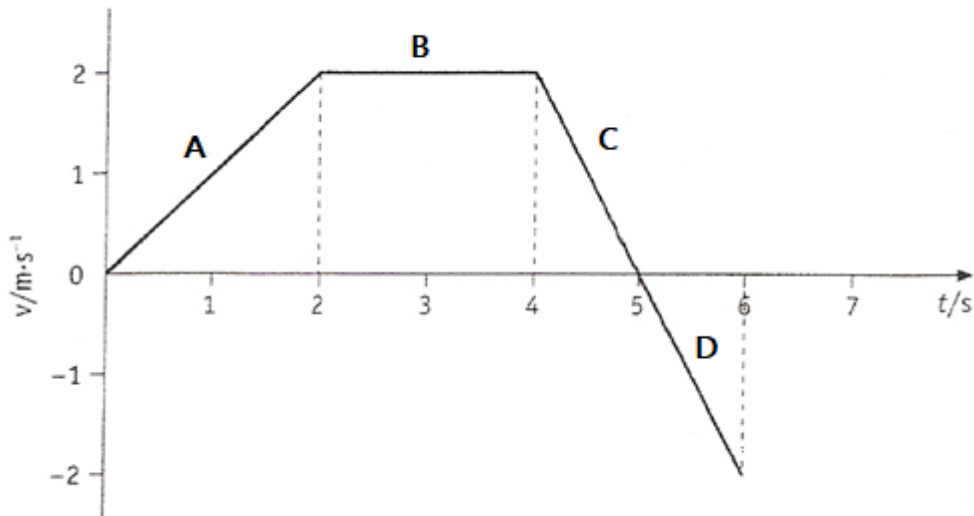

- 7.1 Describe the motion of the object during the first 2 s. (2)
- 7.2 Calculate the acceleration of the object during the last 2 s of its motion. (3)
- 7.3 Calculate the total distance travelled by the object in 5 s. (5)
- 7.4 Calculate the average speed of the object for the first 5 s. (3)
- 7.5 Draw the corresponding displacement-time graph for the entire motion of the object. Break the motion up into sections A,B,C and D and show the time interval on the x-axis. (4)

[17]

Question 8

A car heads towards the dockyard. The car is travelling too fast, and the driver slams on brakes and tries to stop before the car goes over the edge and falls into the water. The car is moving at $33 \text{ m}\cdot\text{s}^{-1}$ when the driver applies the brakes. The man's reaction time is $0,3 \text{ s}$ and the dock is 50 m long.



- 8.1 What is the car's speed in $\text{km}\cdot\text{h}^{-1}$? (1)
- 8.2 Define acceleration. (2)
- 8.3 Calculate the distance the car travelled during the reaction time. (2)
- 8.4 Determine the deceleration needed for the car to stop before going over the edge of the dock. (5)

[10]

**DATA FOR PHYSICAL SCIENCES GRADE 10
PAPER 1 (PHYSICS)
TABLE 1: PHYSICAL CONSTANTS**

NAME	SYMBOL	VALUE
Speed of light in a vacuum	c	$3,0 \times 10^8 \text{ m}\cdot\text{s}^{-1}$
Speed of sound in air	$v_{(\text{air})}$	$340 \text{ m}\cdot\text{s}^{-1}$
Speed of sound in water	$v_{(\text{water})}$	$1500 \text{ m}\cdot\text{s}^{-1}$
Planck's constant	h	$6,63 \times 10^{-34} \text{ J}\cdot\text{s}$
Charge on electron	e^-	$-1,6 \times 10^{-19} \text{ C}$
Coulomb's constant	k	$9 \times 10^{-9} \text{ N}\cdot\text{m}^2 \text{ C}^{-2}$
Gravitational acceleration	g	$9,8 \text{ m}\cdot\text{s}^{-2}$

FORMULAE MOTION

$v_f = v_i + a\Delta t$	$\Delta x = v_i\Delta t + \frac{1}{2}a\Delta t^2$	$v_f^2 = v_i^2 + 2a\Delta x$	$\Delta x = \left(\frac{v_f + v_i}{2}\right)\Delta t$
-------------------------	---	------------------------------	---

FORMULAE WAVES, LIGHT AND SOUND

$v = f\lambda$	$T = \frac{1}{f}$	$E = hf \quad E = h\frac{c}{\lambda}$
$\Delta x = v\Delta t$		$c = f\lambda$

FORMULAE ELECTRICITY AND MAGNETISM

$I = \frac{Q}{\Delta t}$	$V = \frac{W}{Q}$	$R = \frac{V}{I}$	$Q = \frac{Q_1 + Q_2}{2}$
$\frac{1}{R_p} = \frac{1}{R_1} + \frac{1}{R_2} + \dots$	$R_s = R_1 + R_2 + \dots$		$F = \frac{k Q_1 Q_2}{r^2}$
$P = \frac{W}{t}$			$n = \frac{Q}{e}$

