

# Hillcrest High School

## PHYSICAL SCIENCE

### PAPER 1

NOVEMBER 2023

Grade 10

**EXAMINER:** Mrs Smith

**MARKS:** 140

**MODERATORS:** Ms Badenhorst & Mrs Knox-Whitehead

**TIME:** 2 Hours

#### INSTRUCTIONS

1. This question paper consists of **11 questions** and **TWO sections**:  
SECTION A (20)  
SECTION B (120)
2. Write legibly and neatly.
3. Answer ALL the questions in the ANSWER BOOK.
4. Leave one line between two sub- questions e.g between QUESTION 2.1 and QUESTION 2.2
5. Rule off between each QUESTION e.g QUESTION 1 and QUESTION 2
6. Non-programmable calculators and appropriate mathematical instruments may be used.
7. Number the answers correctly according to the numbering system used in this question paper.
8. Data sheets are attached for your use.
9. Show ALL formulae and ALL substitutions in calculation.
10. Give brief motivations, discussions, et cetera where required.
11. Final numerical answers must be rounded off to **two decimal** places.

**SECTION A****QUESTION 1: MULTIPLE CHOICE****(2 x 10 = 20)**

Four options are provided as possible answers to the following questions. Each question has only ONE correct answer. Write only the letter (A – D) next to the question number (1.1 – 1.10) in the ANSWER BOOK.

- 1.1 Which of the following indicates a wave in which the particles of the medium vibrate parallel to the direction of the motion of the wave?
- A radio waves  
B transverse waves  
C sound waves  
D light waves
- 1.2 Which graph represents the relationship between the frequency and the speed of light waves in a vacuum?

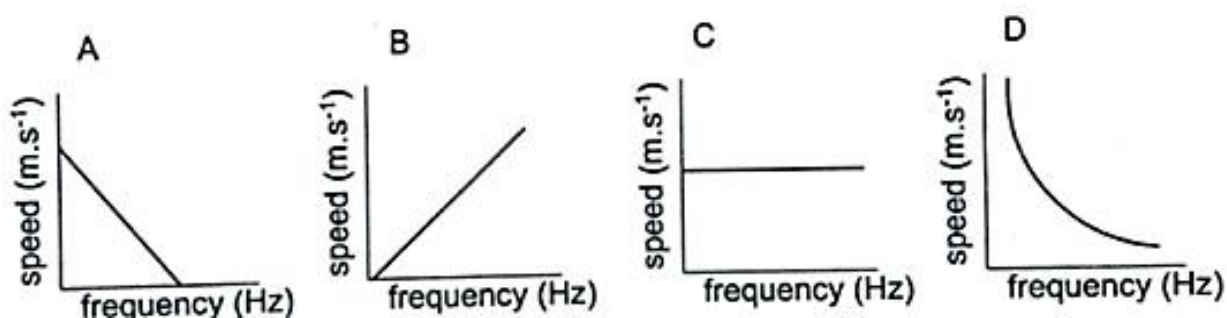

- 1.3 John wants to **decrease** the resistance of an electrical circuit and has the following options:
- (i) increase the length of the nichrome conductor  
(ii) increase the thickness of the nichrome conductor  
(iii) use a copper conductor instead of a nichrome conductor

Which combination of his options would best reduce the resistance of the circuit?

- A (i), (ii) and (iii)  
B (i) and (ii)  
C (i) and (iii)  
D (ii) and (iii)

- 1.4 The work done per unit charge by a battery is the
- A voltage
  - B current
  - C resistance
  - D power

- 1.5 Three  $3\ \Omega$  resistors are connected between point X and point Y, as shown in the diagram below.

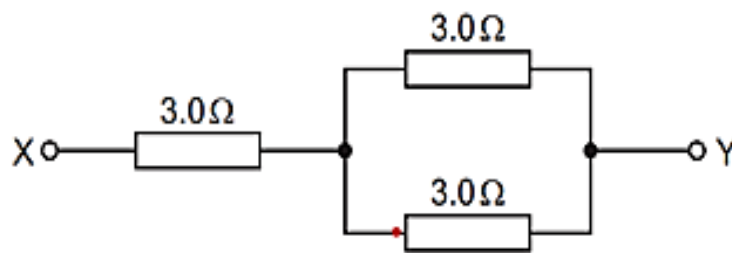

What is the resistance between point X and point Y?

- A  $3.0\ \Omega$
  - B between  $3.0\ \Omega$  and  $6.0\ \Omega$
  - C between  $6.0\ \Omega$  and  $9.0\ \Omega$
  - D  $9.0\ \Omega$
- 1.6 Consider the circuit diagram below. Which is the correct relationship between the voltmeter readings?

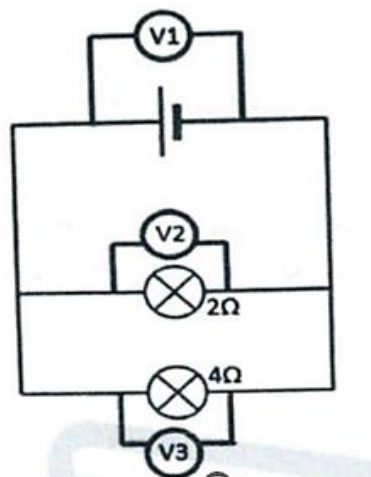

- A  $V_2 = V_3$
- B  $V_3 = 0,5 V_2$
- C  $V_2 = 0,5 V_3$
- D  $V_1 = V_2 + V_3$

1.7 A positively charged rod is brought near the following objects :

- (i) small, uncharged pieces of paper
- (ii) a thin stream of water
- (iii) a positively charged balloon
- (iv) a negatively charged cloth

Which of these objects will **not** be attracted to the rod?

- A (i) , (ii) and (iii)
- B (i) and (ii)
- C (ii) and (iii)
- D (iii)

1.8 A car accelerates uniformly from rest. It then travels at a constant speed for a certain time and finally it stops suddenly.

Which diagram represents the speed vs time graph for the motion of the car?

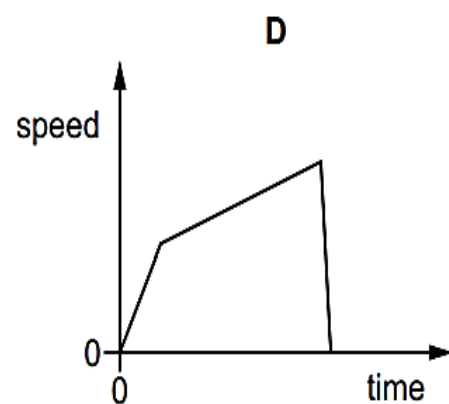
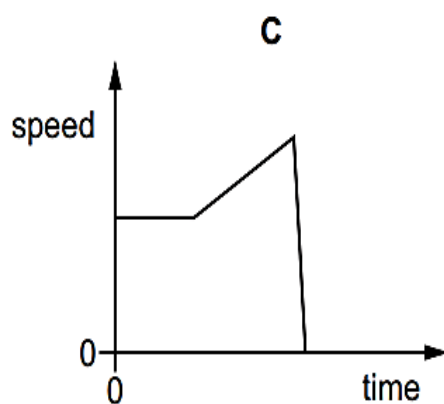
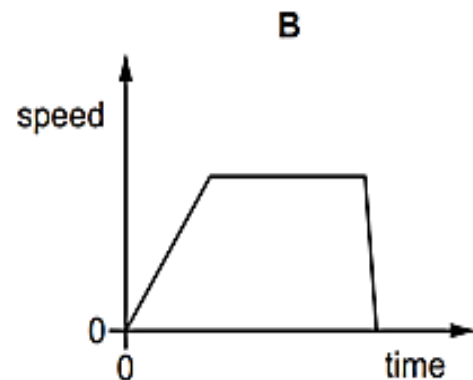
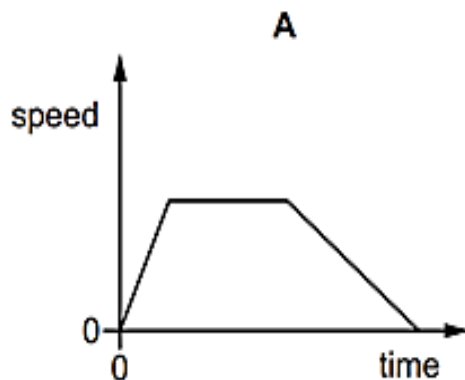

1.9 A truck is travelling at a constant velocity along a straight road. As it travels up a steep hill, it slows down uniformly. Which one of the following velocity vs time graphs best represents the motion of the truck?

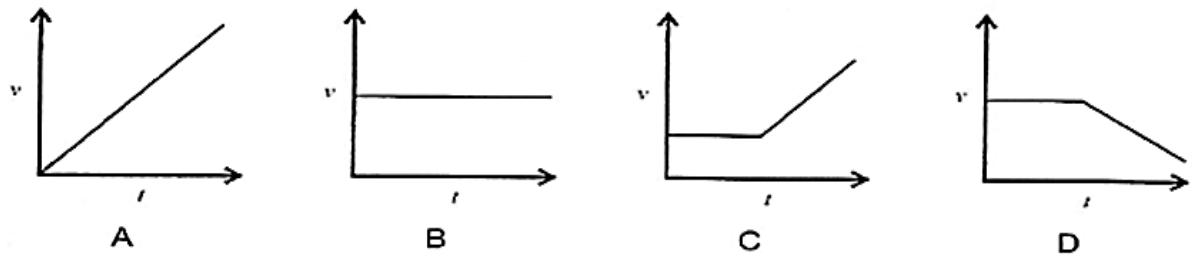

1.10 Which diagram shows the greatest resultant displacement?

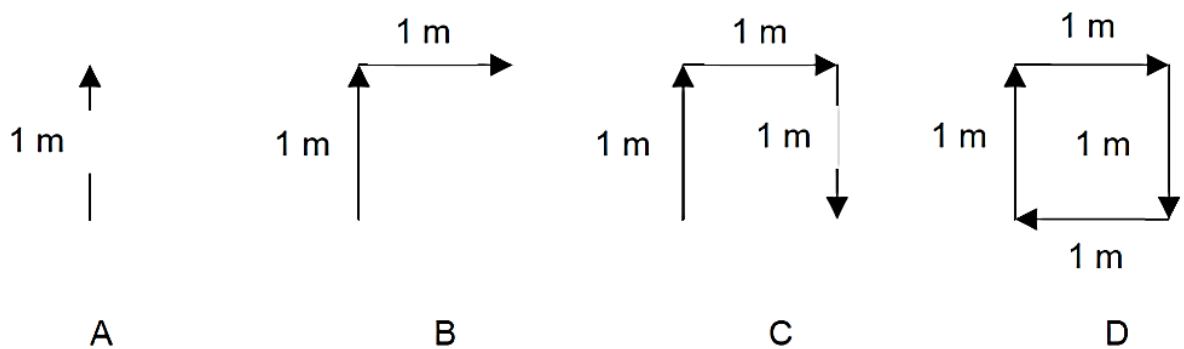

**SECTION A (20)**

**QUESTION 2**

(9)

Study the two transverse waves, P and Q, as shown below.

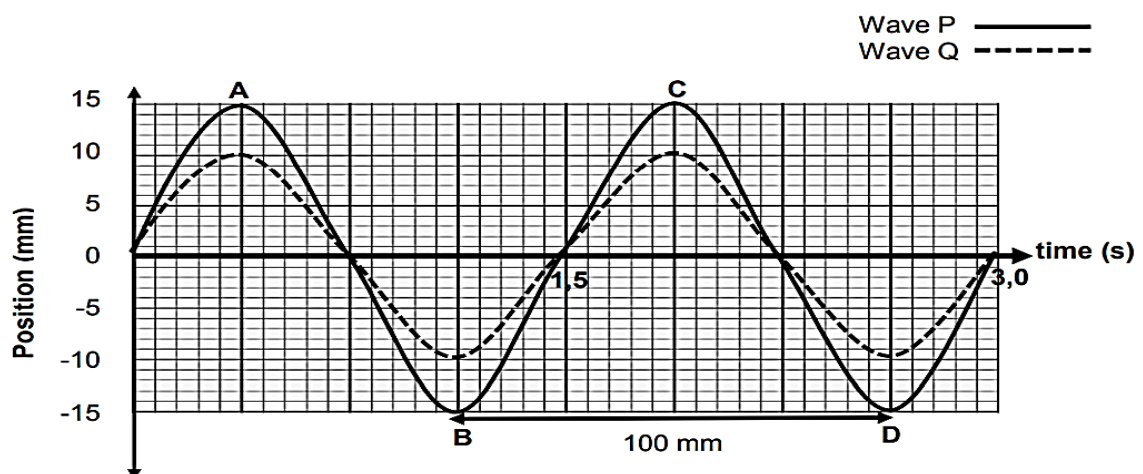

2.1 Write down one difference between wave P and Q.

(1)

2.2 For wave pattern P, write down:

2.2.1 two points that are out of phase (1)

2.2.2 the amplitude of the wave (1)

2.3 For wave pattern Q, calculate:

2.3.1 the frequency of the wave (3)

2.3.2 the speed of the wave (3)

---

**QUESTION 3**

**(8)**

A man standing between 2 buildings, as shown in the diagram below, sounds a siren. He hears an echo of the sound produced by the siren from **building 1** after a time of 8 seconds, and an echo from **building 2** after a time of 6 seconds.

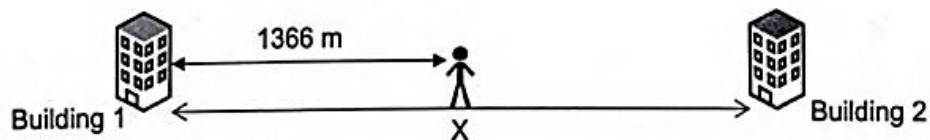

The distance between the man and **building 1** is 1366m.  
(The man and both buildings are on a straight line.)

Calculate:

3.1 the speed of sound in air (4)

3.2 the distance **X** between the two buildings (4)

---

**QUESTION 4****(9)**

The table below displays the data for different types of electromagnetic radiation in order of increasing energy.

TYPE OF RADIATION	ENERGY (J)
radio waves	$2,65 \times 10^{-27}$
microwaves	$1,99 \times 10^{-23}$
infrared (IR)	$3,95 \times 10^{-22}$
visible light	$1,33 \times 10^{-19}$
ultraviolet light (UV)	$4,64 \times 10^{-18}$
X-rays	$9,95 \times 10^{-17}$
radiation Y	$2,32 \times 10^{-14}$

- 4.1 Identify the type of radiation represented by radiation Y. (1)
- 4.2 Write down the energy value for the type of radiation with the highest frequency. (1)
- 4.3 Determine both:
- 4.3.1 the frequency, and (3)
- 4.3.2 the wavelength of visible light (3)
- 4.4 Discuss **one** use of infrared radiation. (1)

**QUESTION 5****(14)**

Study the circuit diagram below. The three resistors are identical, and each has a resistance of  $6\Omega$ . Voltmeter  $V_1$  has a reading of 12V.

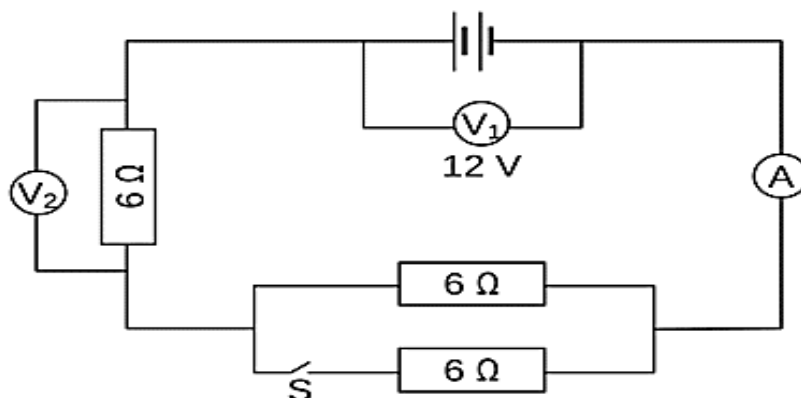

- 5.1 **THE SWITCH (S) IS INITIALLY OPEN.**

Calculate:

5.1.1 the reading on the ammeter (4)

5.1.2 the reading on voltmeter  $V_2$  (3)

5.2 **THE SWITCH (S) IS NOW CLOSED.**

5.2.1 What happens to the total resistance of the circuit?  
(Choose from **INCREASES / DECREASES / REMAINS THE SAME**) (1)

5.2.2 Calculate the new reading on the ammeter. (6)

**QUESTION 6**

**(13)**

6.1 A charger for a cell phone produces a current of 50mA for 90 minutes.  
The charger has a power rating of 5W.

Calculate

6.1.1 the amount of charge that passes through the charger during this time (3)

6.1.2 the cost of using the charger for this time if a kWh costs R2,75 (3)

6.2 An electric kettle is connected to a 220V power supply.  
It takes 4 minutes to boil the kettle, during which time 580,8kJ of heat energy is transferred to the water.

Calculate

6.2.1 the current flowing into the kettle (4)

6.2.2 the power rating of the kettle (3)

**QUESTION 7**

**(17)**

Two small identical spheres, P and R, are suspended on long silk threads, as shown in the diagram below.

Sphere P is initially neutral and the initial charge on sphere R is unknown.

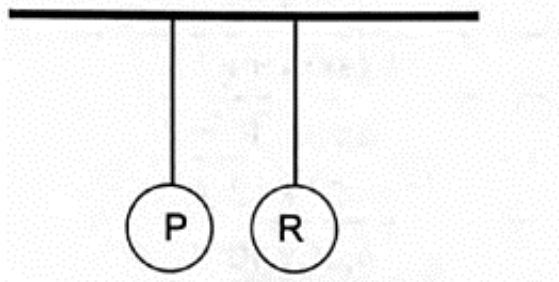

Sphere **P** is rubbed with a cloth and gains  $2 \times 10^{13}$  electrons.

7.1 Determine the charge on sphere **P** after gaining the electrons. (3)

- 7.2 State the *Principle of Conservation of Charge* in words. (1)
- 7.3 Sphere **P** is now brought into contact with sphere **R** and the two spheres are then separated. Both spheres have a new charge of  $6,4 \mu\text{C}$  after separation.
- Calculate
- 7.3.1 the initial charge on sphere **R** (4)
- 7.3.2 the number of electrons transferred from sphere **P** to sphere **R** (4)
- 7.4 After contact, a force of  $2 \times 10^{-5} \text{ N}$  exists between the two spheres.
- 7.4.1 State whether the force is attraction or repulsion. (1)
- 7.4.2 Calculate the distance between sphere **P** and **R**. (4)

**QUESTION 8****(12)**

During a practice session, a basketball player runs around the court starting from point A. He runs clockwise, to point B, C, D and then returns to point A. It takes the player 20 seconds to complete one lap.

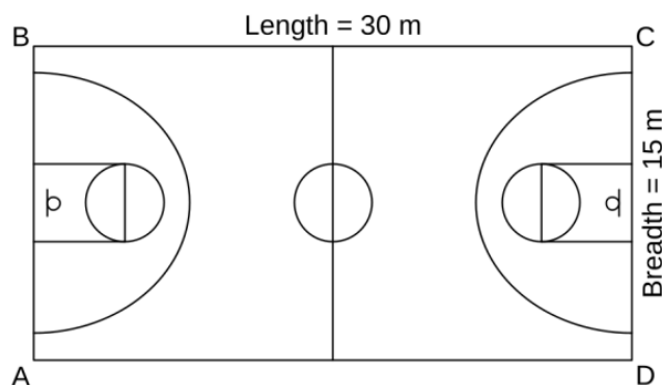

- 8.1 Calculate
- 8.1.1 the distance he covers after completing one lap. (2)
- 8.1.2 his average speed for the lap. (3)
- 8.2 Define the term '*displacement*'. (2)
- 8.3 Calculate the magnitude of his displacement as he reaches point C. (3)
- 8.4 State
- 8.4.1 what his displacement will be as he returns to point A. (1)
- 8.4.2 what his average velocity will be for the entire lap. (1)

**QUESTION 9****(9)**

A cyclist taking part in a cycling competition slows uniformly as he reaches the end of the race. He eventually comes to rest from a velocity of  $35 \text{ m}\cdot\text{s}^{-1}$  in 5 seconds.

9.1 Define the term 'acceleration'. (2)

Calculate:

9.2 The acceleration of the cyclist. (4)

9.3 How far the cyclist travelled from when he started applying the brakes. (3)

**QUESTION 10****(21)**

The velocity vs time graph for a racing car originally moving eastwards, is shown below.

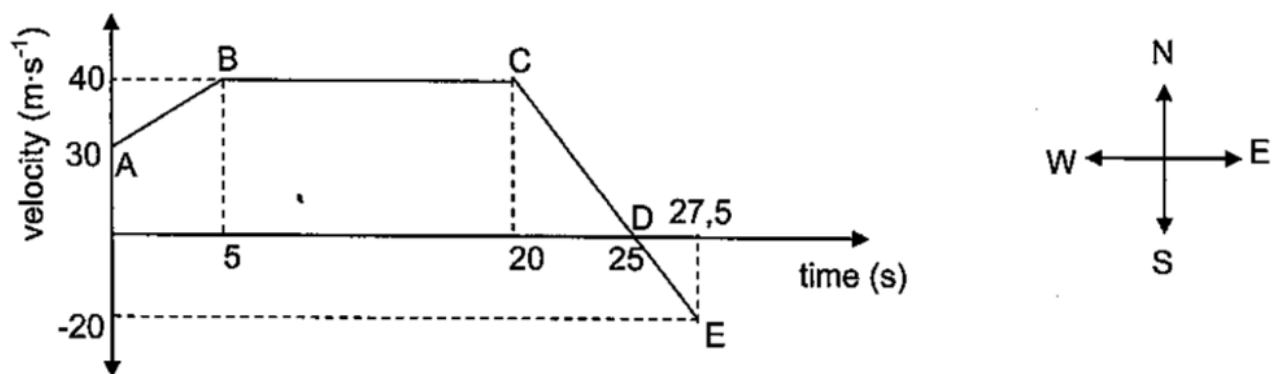

10.1.1 Is velocity a scalar or a vector quantity? (1)

10.1.2 Explain your answer to QUESTION 10.1.1. (1)

10.2 Write down the initial velocity of the car. (2)

10.3 Write down the speed of the car at time  $t = 10 \text{ s}$ . (1)

10.4.1 Describe fully the motion of the car for the section labelled **CD**, mentioning information provided on both sets of axes. (3)

10.4.2 Support your answer to QUESTION 10.4.1 above by calculating the acceleration for section **CD**. (4)

10.5.1 Without any calculation, compare the magnitude of the acceleration of the car in section **DE** with that in section **CD** of the journey. Write only **GREATER THAN**, **LESS THAN** or **EQUAL TO**. (1)

10.5.2 Give a reason for your answer to QUESTION 10.5.1. (1)

10.6 Using only the graph, determine the total displacement for the motion of the car. (7)

**QUESTION 11****(8)**

A car is driving at  $20\text{m}\cdot\text{s}^{-1}$  when the driver sees a traffic officer at a speed trap 100m away. The driver realizes he is travelling too fast and applies the brakes of the car. His reaction time to step on the brakes is 1 second. The speed limit on this road is  $16,66\text{ m}\cdot\text{s}^{-1}$ .

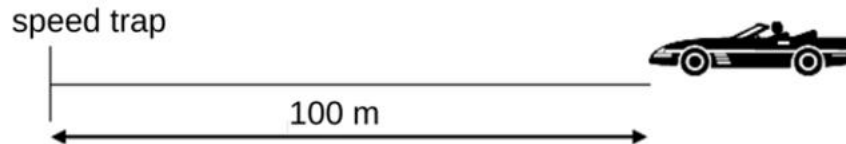

- 11.1 Calculate how far the car moves from the time the driver first notices the speed trap until he applies his brakes. (3)
- 11.2 Calculate how long it takes him to reach the speed trap from the time he applied his brakes, if his speed is  $16\text{ m}\cdot\text{s}^{-1}$  when he reached the speed trap. (5)

**TOTAL SECTION B (120)****GRAND TOTAL (140)**

**DATA FOR PHYSICAL SCIENCES GRADE 10  
PAPER 1 (PHYSICS)**

**TABLE 1: PHYSICAL CONSTANTS**

**FORMULAE MOTION**

$v_f = v_i + a \Delta t$	$\Delta x = v_i \Delta t + \frac{1}{2} a \Delta t^2$	$v_f^2 = v_i^2 + 2a \Delta x$	$\Delta x = \left( \frac{v_f + v_i}{2} \right) \Delta t$
--------------------------	--	-------------------------------	--

**FORMULAE WAVES, LIGHT AND SOUND**

$v = f \lambda$	$T = \frac{1}{f}$	$E = hf$ $E = h \frac{c}{\lambda}$
$\Delta x = v \Delta t$		$c = f \lambda$

**FORMULAE ELECTRICITY AND ELECTROSTATICS**

$I = \frac{Q}{\Delta t}$	$V = \frac{W}{Q}$	$R = \frac{V}{I}$	$Q = \frac{Q_1 + Q_2}{2}$
$W = I^2 R t$	$W = V I t$	$W = \frac{V^2 t}{R}$	$F = k \frac{Q_1 Q_2}{r^2}$
$P = IV$	$P = \frac{W}{t}$	$P = I^2 R$	$n = \frac{Q}{q_e}$
$R_s = R_1 + R_2 + \dots$	$\frac{1}{R_p} = \frac{1}{R_1} + \frac{1}{R_2} + \dots$		

**CONSTANTS**

NAME	SYMBOL	VALUE
Speed of light in a vacuum	c	$3 \times 10^8 \text{ m}\cdot\text{s}^{-1}$
Planck's constant	h	$6,63 \times 10^{-34} \text{ J}\cdot\text{s}$
Charge on electron	$e^-$	$-1.6 \times 10^{-19} \text{ C}$
Coulomb's constant	k	$9 \times 10^9 \text{ N}\cdot\text{m}^2 \text{ C}^{-2}$
Gravitational acceleration	g	$9,8 \text{ m}\cdot\text{s}^{-2}$