

# HILLCREST HIGH SCHOOL



## NATURAL SCIENCE EXAM

**GRADE 8**

**EXAMINER: MRS SMITH**

**MODERATOR : MRS PRIOR**

**NOVEMBER 2024**

**TOTAL: 100 MARKS**

**TIME : 2 HOURS**

---

### INSTRUCTIONS

1. This question paper consists of 12 pages and 14 questions
2. Answer all the questions in the ANSWER BOOK provided.
3. Non-programmable calculators may be used.
4. Number the answers correctly according to the numbering system used in this question paper.
6. Give brief motivations, discussions, et cetera where required.
7. Calculations must be rounded off to two decimal places where appropriate.
8. Leave a line between each answer and RULE OFF after each question 1 – 14.

**QUESTION 1 : MULTIPLE CHOICE**

**(10 x 1 = 10)**

For each question, Q 1.1 to Q 1.10 there is only one correct answer.

Write down only the number followed by the letter (A – D) of your choice E.g 1.11 D

1.1 Which one of the following spheres is electrically neutral?

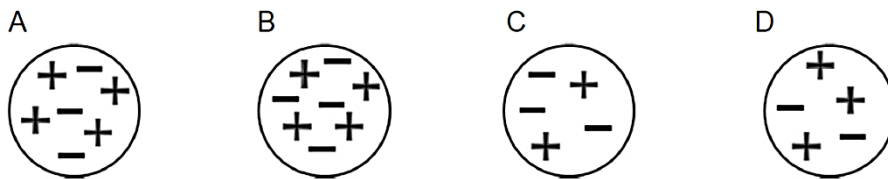

1.2 A girl combs her hair with a plastic comb. The comb becomes negatively charged. Some of her hair moves toward the comb as she moves the comb away. Her hair has ...

- A lost electrons
- B gained electrons
- C gained protons
- D lost protons

1.3 In the circuit on the right, switches  $S_1$  and  $S_2$  are closed. What will happen if switch  $S_3$  is closed, and then switch  $S_4$ ?

- A The bulb C will glow dimmer than bulb A
- B The total resistance decreases, and the total current increases
- C The total resistance and total current remains the same
- D The total resistance increases, and the total current decreases

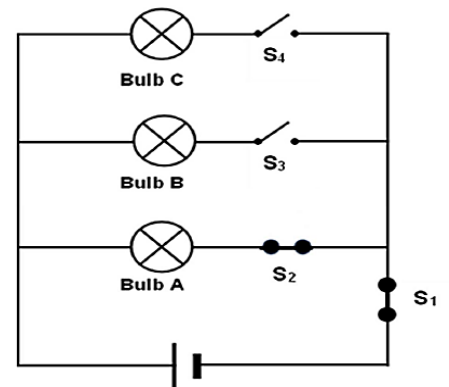

1.4 The colour a red flower will appear in blue light is

- A red
- B blue
- C black
- D white

1.5 The three sketches below, a, b and c (in that order) are said to be

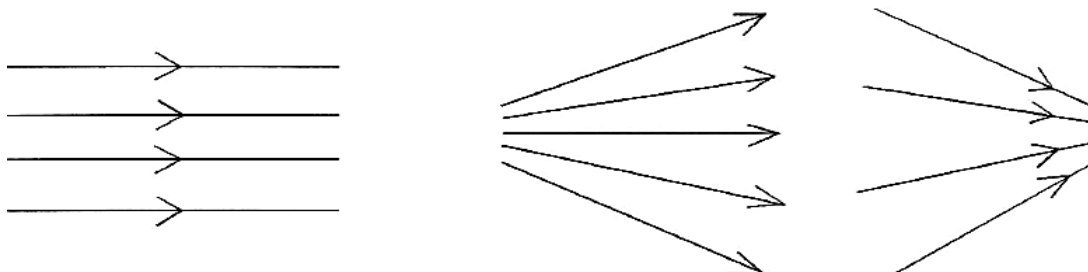

- A parallel, diverging, converging
- B converging, parallel, diverging
- C diverging, converging, parallel
- D parallel, converging, diverging

1.6 The Oort Cloud is located

- A in the Earth's atmosphere
- B between Mars and Jupiter
- C between Neptune and Pluto
- D beyond Pluto

1.7 The main gases found in the Sun are

- A hydrogen and helium
- B helium and oxygen
- C hydrogen and nitrogen
- D oxygen and carbon dioxide

1.8 The distance between the Sun and Earth is approximately

- A 150 million light years
- B 4.2 light years
- C one light year
- D 8 light minutes

1.9 A celestial body that comes that 'grows' a bright tail as it approaches the Sun is called

- A a meteor
- B an asteroid
- C a comet
- D a constellation

1.10 What is the Andromeda Spiral?

- A A planet
- B A galaxy
- C A comet
- D A constellation

## **QUESTION 2 : MATCHING COLUMNS**

**(5 x 1 = 5)**

**Choose the term from COLUMN B that best matches the description in COLUMN A.**

**Write only the letter (A– H) next to the question number (2.1 – 2.5)**

<b>COLUMN A</b>	<b>COLUMN B</b>
2.1 protective covering in the eye that protects the pupil	A opaque
2.2 a substance light cannot pass through	B retina
2.3 an object that gives off light is said to be	C luminous
2.4 sensory layer at the back of the eye where light gathers to form an image	D cornea
2.5 clear glass is said to be	E transparent
	F optic nerve
	G reflection
	H lens

**QUESTION 3**

**(3)**

The two diagrams below show the interactions between balloons **W**, **X** and **Y**.

- balloon **X** has a negative charge in each of the diagrams
- balloons **W** and **Y** could be either positive or negative

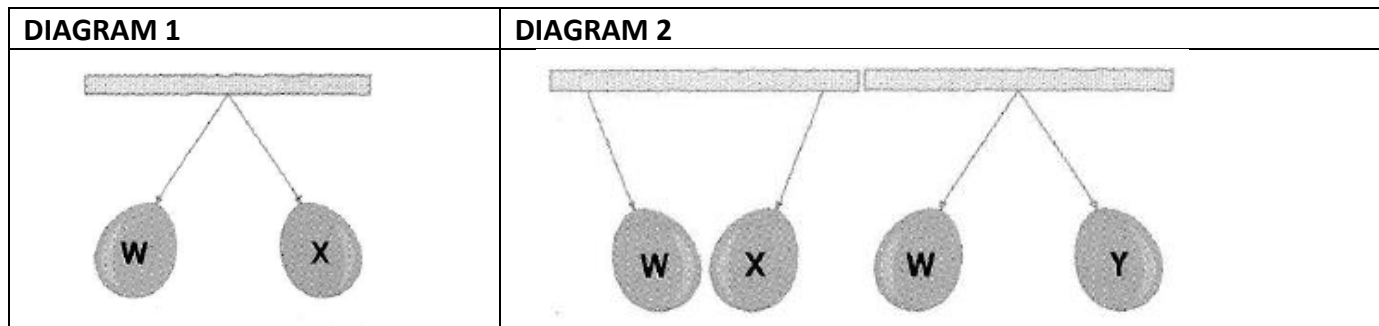

**CONSIDER DIAGRAM 1**

- 3.1 Determine the charge on balloon **W**. (1)
- 3.2 Give one visible reason for your answer above. (1)

**CONSIDER DIAGRAM 2**

- 3.3 Determine the charge on balloon **Y**. (1)

**QUESTION 4**

**(9)**

In each of the pictures (A to C), an effect of electric current is demonstrated.

<p><b>A</b></p>	<p><b>C</b></p>
<p><b>B</b></p>	

- 4.1 What effect of an electric current is demonstrated in
- a) picture **A** (1)
  - b) picture **B** (1)
  - c) picture **C** (1)
- 4.2 Describe **TWO** ways in which the effect produced in picture **B** can be increased. (2)
- 4.3 Consider picture **C**
- a) Identify the reddish brown substance formed on the cathode. (1)
  - b) Give the correct name for the positive electrode. (1)
  - c) Identify the bubbles formed on the positive electrode. (1)
  - d) What process is taking place in the beaker? (1)
- 

**QUESTION 5 : TERMINOLOGY** (5)

Give the correct word or term for each of the following statements.

- 5.1 The galaxy in which Earth is located. (1)
  - 5.2 A free-floating rock in outer space. (1)
  - 5.3 A collection of planets orbiting a star. (1)
  - 5.4 The force holding a galaxy together. (1)
  - 5.5 Also called a 'shooting star'. (1)
-

**QUESTION 6**

**(5)**

The light bulbs and the cells in circuits A, B and C are identical.

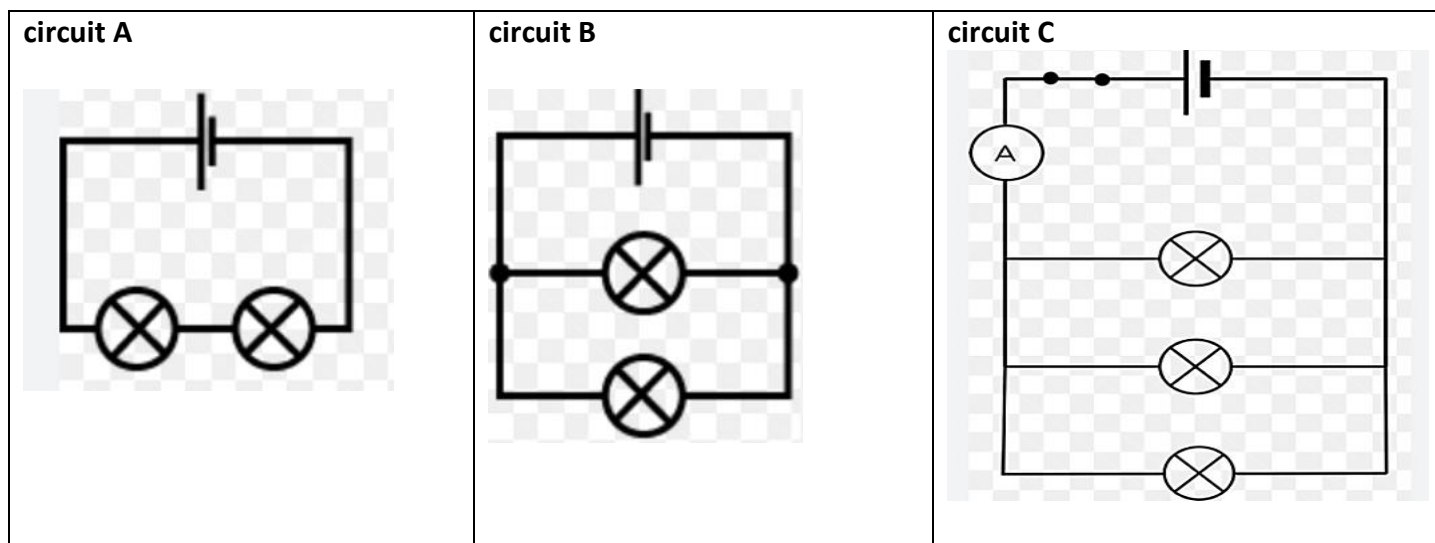

Which circuit (choose **A**, **B** or **C**):

- 6.1 has two bulbs connected in parallel (1)
- 6.2 has the lowest total current (1)
- 6.3 has the dimmest bulbs (1)
- 6.4 has the lowest total resistance (1)
- 6.5 has an ammeter (1)

**QUESTION 7**

**(5)**

The light bulbs and the cells in circuits **A** to **H** are identical.

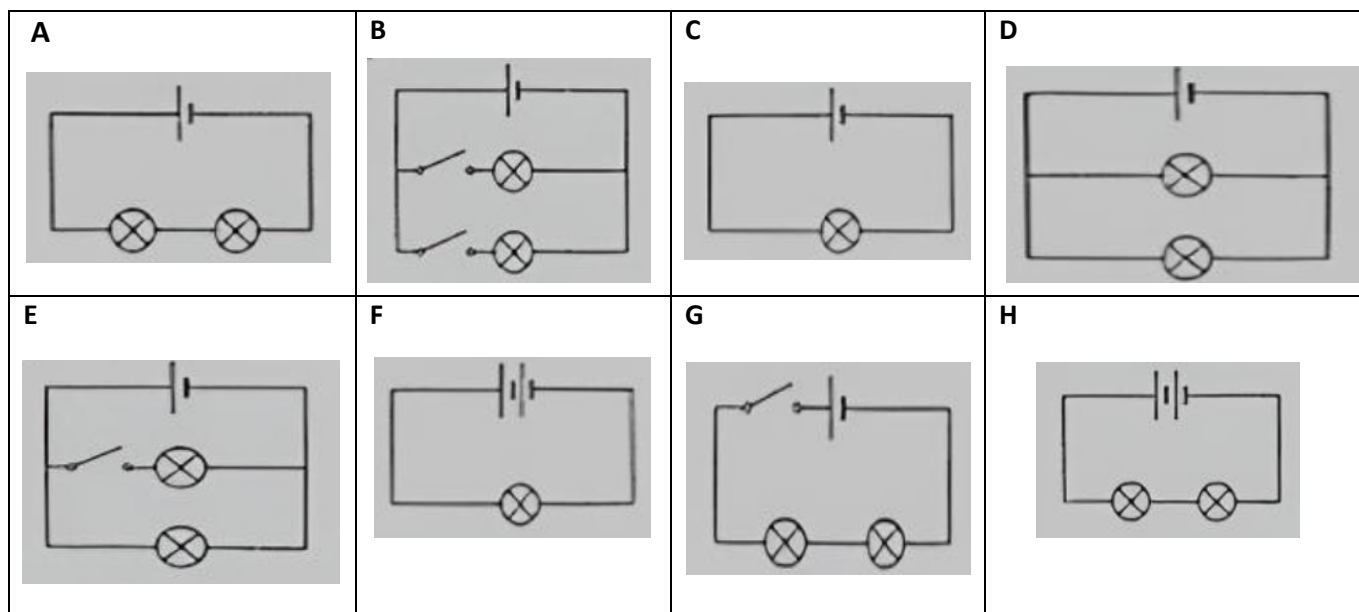

- 7.1 Write down the letter of a circuit that has two bulbs controlled by one switch. (1)
- 7.2 Write down the letter of a series circuit that has bulbs as bright as circuit **G** when the switch on **G** is closed. (1)
- 7.3 a) Write down the letter of a circuit that has two bulbs you can turn on and off independently. (1)
- b) Explain why you have chosen this circuit. (1)
- 7.4 If all the switches were open, in which circuit/s would none of the bulbs shine? (1)

**QUESTION 8****(7)**

Study the diagram below and answer all the questions that follow:

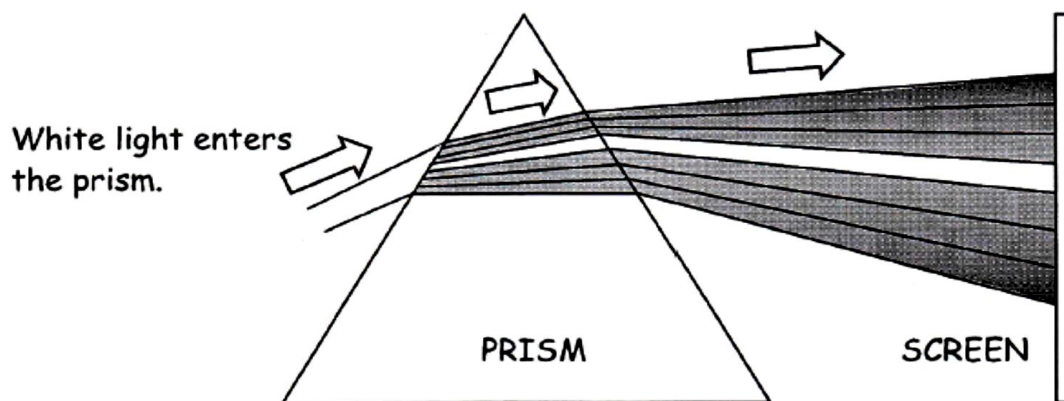

- 8.1 Give the term for the spreading out of white light through a prism into its seven component colours. (1)
- 8.2 Write the names of the colours appearing on the screen in order, from top to bottom. (1)
- 8.3 Which of these colours ...
- is refracted the most? (1)
  - is slowed down the least and emerges first from the prism? (1)
  - has the highest frequency? (1)
  - has the longest wavelength? (1)
- 8.4 What name is given to the natural phenomenon that occurs when sunlight passes through water droplets in the atmosphere? (1)

**QUESTION 9****(5)**

The diagram below shows a ray of light passing from air into a transparent glass block.

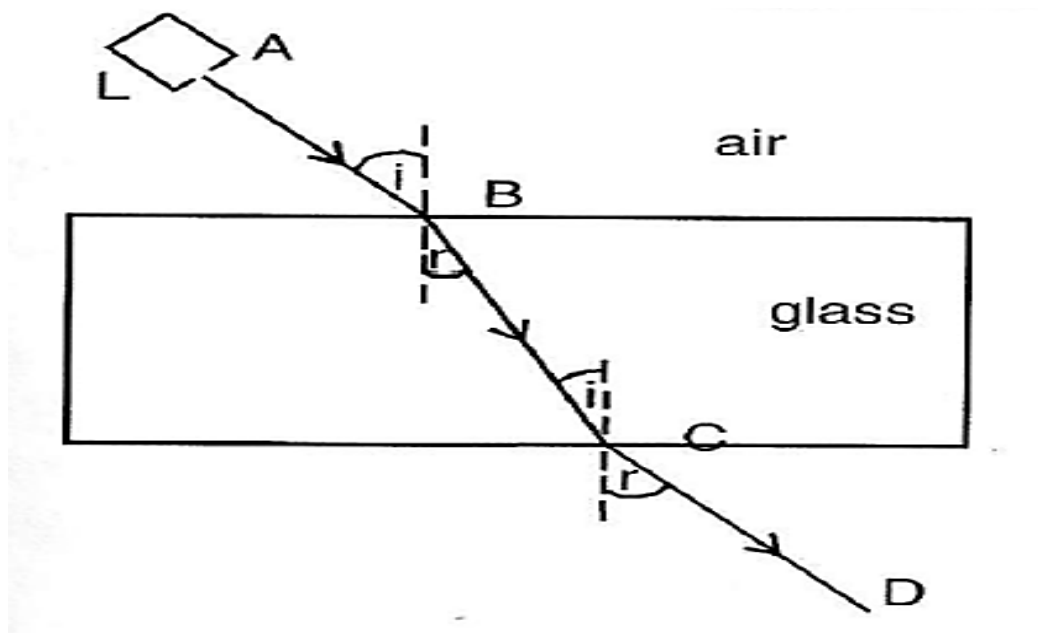

Read the following paragraph and choose the correct answer from the words in the brackets.

Write down only the question numbers (9.1 – 9.5) in the margin, followed by the answer.

Do **NOT** re-write the sentences.

- 9.1 As a light ray enters the glass at **B**, it moves into an optically (**more dense / less dense**) medium. (1)
- 9.2 This causes the light ray to (**speed up / slow down**) through the glass. (1)
- 9.3 The light rays then bend (**towards / away from**) the normal. (1)
- 9.4 As a result, the angle of incidence at point **B** is (**bigger / smaller**) than the angle of refraction at point **C**. (1)
- 9.5 Ray **AB** is parallel to (**ray BC / ray CD**). (1)

**QUESTION 10**

**(8)**

Study the ray diagram showing reflection and answer the questions that follow.

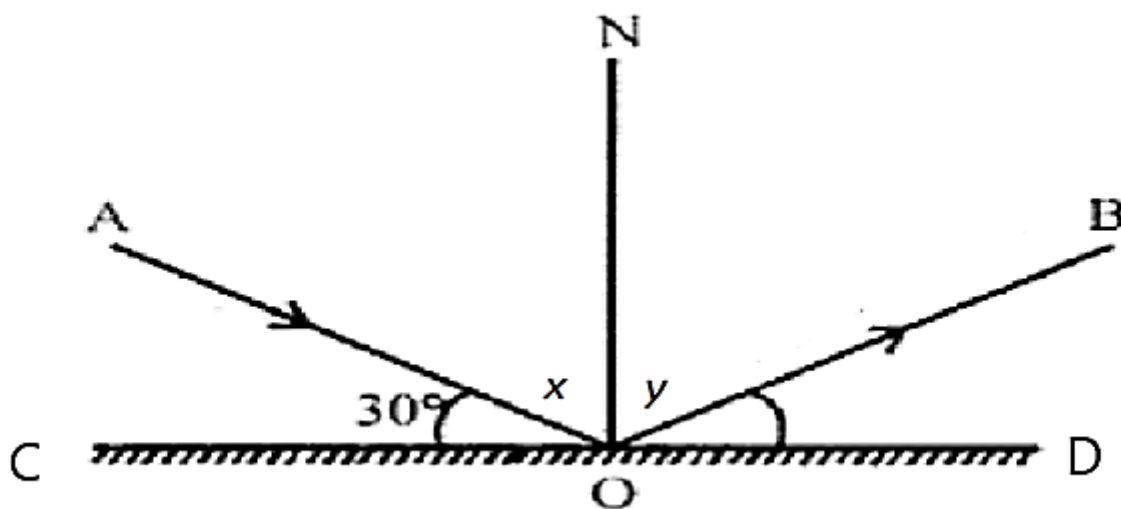

10.1 What property of light is being demonstrated in the diagram? (1)

10.2 Supply the correct labels for the following:

- a) ray **OB** (1)
- b) line **ON** (1)
- c) angle **x** (1)
- d) object **CD** (1)

10.3 Determine the size of the angle **x**. Show ALL your working. (2)

10.4 What relationship exists between the angle of incidence and the angle of reflection? (1)

**QUESTION 11**

**(11)**

The table below gives rotational time information on the movements of some planets in our Solar System.

PLANETS	ROTATIONAL TIME ABOUT THE AXIS (HRS)
Uranus	15
Mercury	50
Mars	30
Jupiter	10

11.1 From the table, identify:

- a) one terrestrial planet (1)
- b) one gas giant (1)
- c) the planet that has the closest rotational time to Earth (1)
- d) the independent variable (1)

11.2 Construct a **bar graph** showing the rotational time of the 4 planets. (5)

11.3 From the graph above, draw a conclusion regarding planets' size and their rotational time. (2)

## **QUESTION 12**

**(11)**

Study the table of planets in our Solar System below and answer all the questions that follow:

PLANET	SIZE DIAMETER (in km)	DISTANCE FROM THE SUN (in km)	ORBITAL TIME (days)	ATMOSPHERIC COMPOSITION	NUMBER OF MOONS	AVERAGE SURFACE TEMP (°C)
Mercury	4 879	57 900 000	88	none	0	- 180 to 430
Venus	12 103	108 200 000	225	CO <sub>2</sub>	0	465
Earth	12 756	149 600 000	365	N <sub>2</sub> , O <sub>2</sub> , H <sub>2</sub> O	1	- 40 to 50
<b>A</b>	6 793	227 900 000	687	CO <sub>2</sub>	2	- 82 to 20
Jupiter	143 000	778 300 000	4 331	H <sub>2</sub> , He	95	- 150
Saturn	120 531	1 427 000 000	10 747	H <sub>2</sub> , He	146	- 170
Uranus	51 113	2 872 500 000	30 589	H <sub>2</sub> , He	27	- 200
<b>B</b>	49 532	4 495 000 000	59 800	H <sub>2</sub> , He	14	- 210

12.1 Supply names for:

- a) planet **A** (1)
- b) planet **B** (1)

12.2 Which planet ...

- a) has the highest temperatures? (1)
- b) has the largest diameter? (1)
- c) is closest to Saturn? (1)
- d) is closest in size to Earth? (1)
- e) has no moons and no atmosphere? (1)

12.3 What relationship exists between the size of the planets and the number of moons they have? (1)

12.4 Suggest **THREE** reasons why Earth is the only planet in our Solar System capable of supporting life. (3)

**QUESTION 13**

**(7)**

Study the images below and answer the questions that follow.



**Image A**



**Image B**

13.1 Identify the **TYPE** of telescope represented by the following:

a) image **A** (1)

b) image **B** (1)

13.2 What do the letters **SALT** stand for? (1)

13.3 Discuss **TWO** reasons why the SALT telescope is located near Sutherland in the Karoo/Northern Cape. (2)

13.4 Name this famous constellation seen in South Africa. (1)

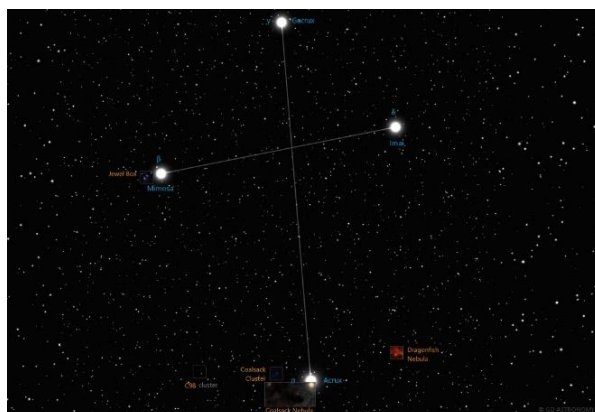

13.5 Halley's Comet was last seen from Earth in 1986. It makes its appearance every 76 years. In what year will it be visible again in South Africa? (1)

**QUESTION 14 : DATA RESPONSE****(9)****MeerKATs IN THE NATIONAL PARK!**

KAT-7 was the first large scale radio telescope to be built in South Africa.

It is situated in the Meerkat National Park. When the South African government increased the budget to allow for the building of 64 dish receptors in the Karoo, the project was renamed MeerKAT, meaning 'more cat', and became operational in 2010. It is now one of the most powerful radio telescopes in the world.

In 2003 South Africa had expressed an interest to be part of the global SKA radio telescope, and so the locally designed and built Meerkat was incorporated into the first phase of the SKA.

The SKA radio telescope will be the world's biggest telescope and will be made up of many large radio receivers that will be linked together across the Earth. The total surface area of all the antennae together will add up to approximately 1 square kilometre.

SKA is special because it will be at least 50 times more powerful and 10 000 times faster than any other radio telescope in the world and is scheduled to be complete in 2024.

The project to build the telescope is international and will be managed by ten countries, namely Australia, Canada, China, Germany, Italy, Netherlands, NZ, South Africa, Sweden and the United Kingdom. But the two main SKA sites will be built in South Africa and Australia. Additional dish receptors will be operational in eight African countries, namely Botswana, Ghana, Kenya, Madagascar, Mauritius, Mozambique, Namibia and Zambia.

- 14.1 In which National Park was the KAT-7 radio telescope built? (1)
- 14.2 What year did KAT – 7 become operational? (1)
- 14.3 How many receptors are now in the MeerKAT project as of 2010? (1)
- 14.4 What do the letters SKA stand for? (1)
- 14.5 What year is this largest telescope in the world due to be completed? (1)
- 14.6 Besides South Africa, name one other country that will manage the SKA. (1)
- 14.7 How many African countries will be connected to the SKA? (1)
- 14.8 Mention **ONE** way that SKA will be superior to any other radio telescope in the world. (1)
- 14.9 Describe **ONE** advantage of radio telescopes over optical telescopes. (1)

**TOTAL 100**

Grade 9 loading.....

