

QUESTION ONE - ANALYTICAL

ANSWERS		
1	2025/01/30	1
2	BOX AND GLAND	1
3	1:2	1
4	HALF SECTION	1
5	325	1
6	BG - 15/4	1
7	RIGHT VIEW	1
8	10 / TEN	1
9	WASHER	1
10	SHAFT	1
11	FILLET	1
12	S-BREAK	1
13	THE SHAFT IS LONGER / INTERRUPTED VIEW	1
14	R3	1
15	A 100 B Ø12	2
16	6 / SIX	1
17	INSERT SPOTFACE	1
18		4
		25

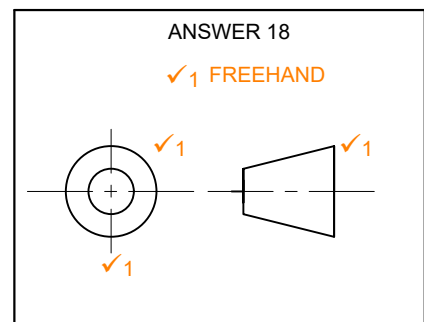

QUESTION ONE
 GRADE 10
 MARKING GUIDELINES

QUESTION TWO
GRADE 10
MARKING GUIDELINES

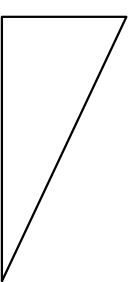
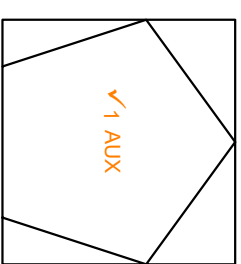
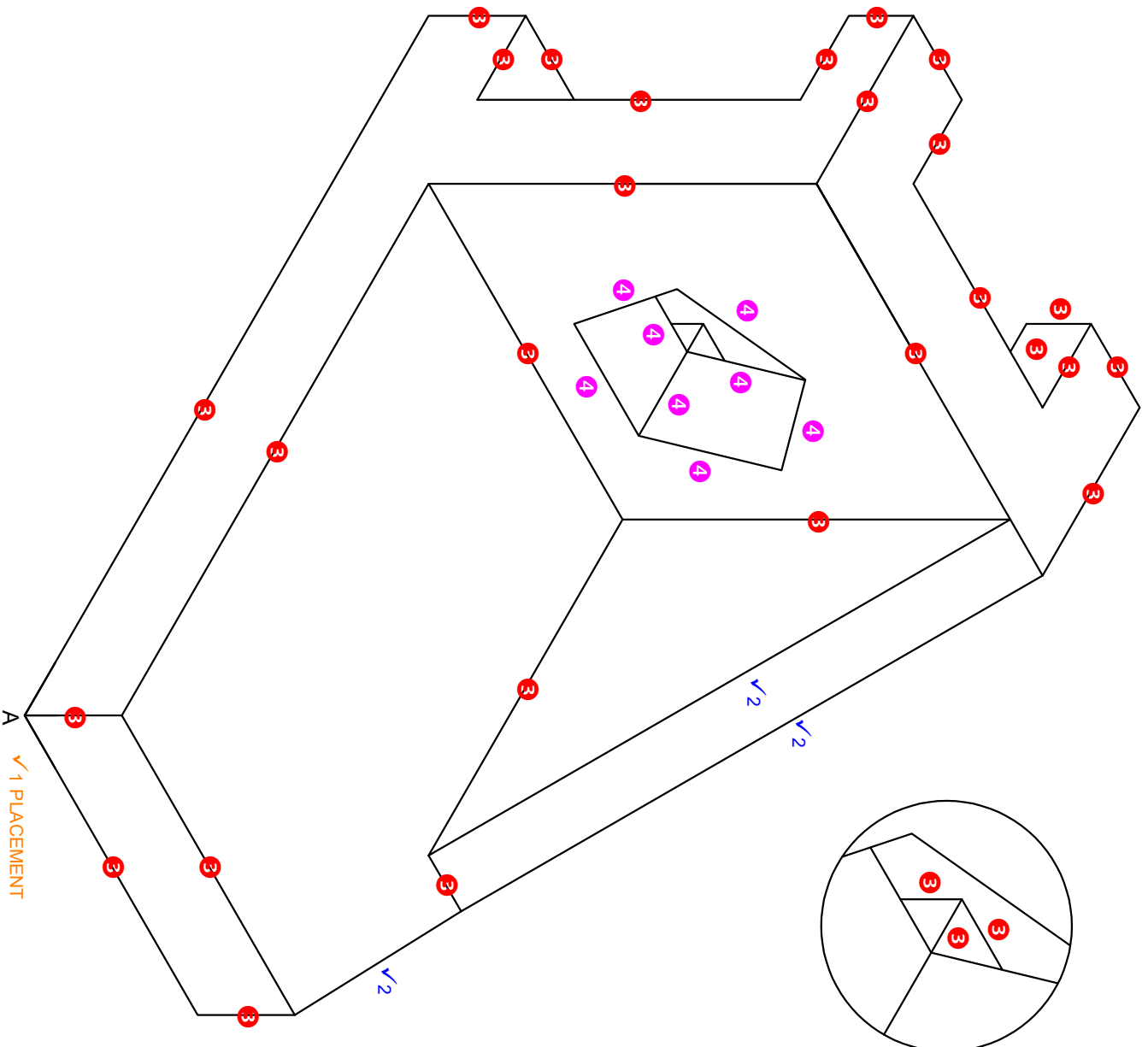

ASSESSMENT CRITERIA

1	PLACEMENT & AUX VIEWS	3		
2	NON-ISOMETRIC LINES	3		
3	ISOMETRIC LINES	15		
4	PENTAGON	4		

PENALTIES (-)

TOTAL	25		
--------------	-----------	--	--

QUESTION THREE
GRADE 10
MARKING GUIDELINES

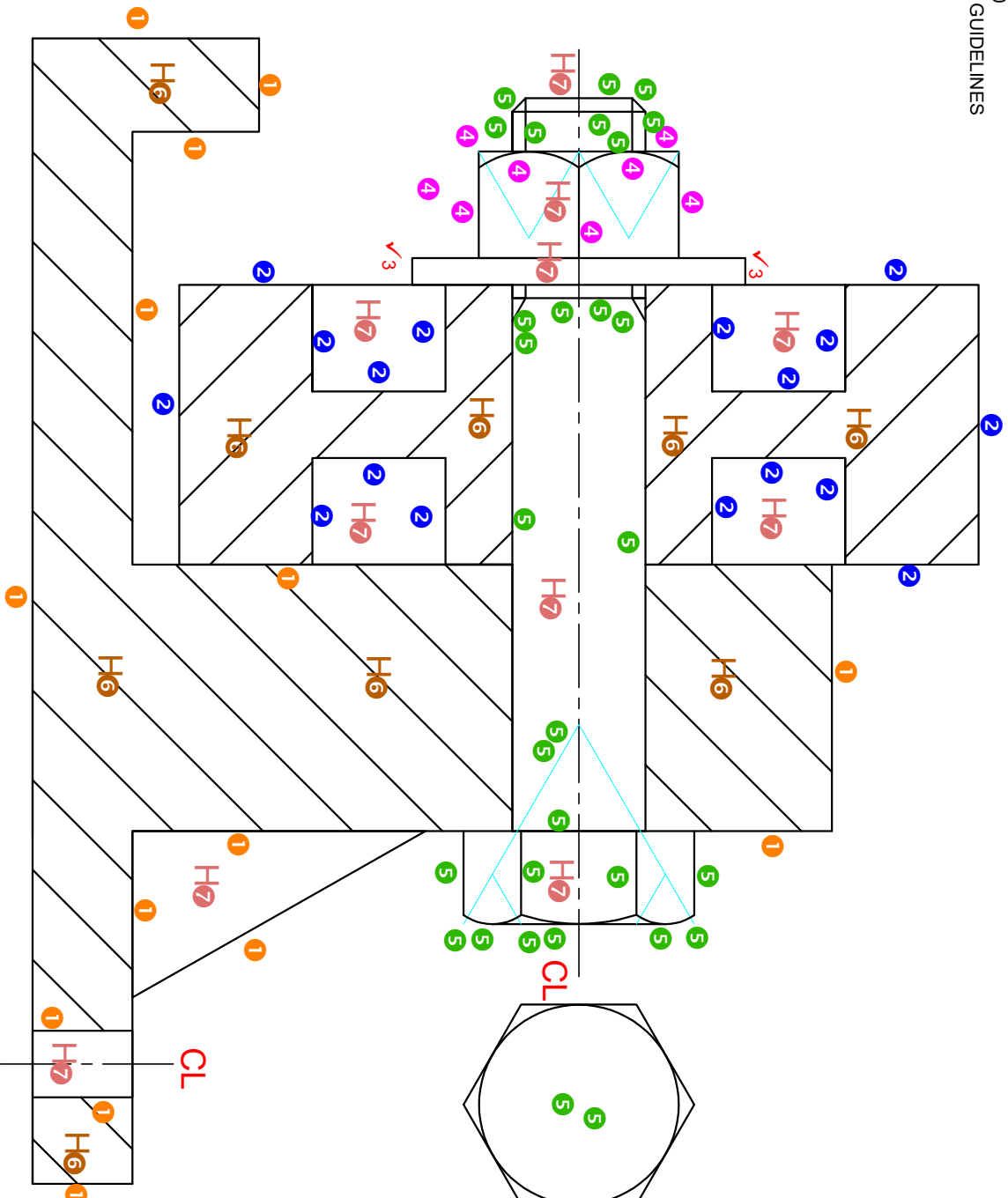

FULL SECTIONAL FRONT VIEW ON A-A / SECTION A-A

PULLEY ASSEMBLY
SCALE 1:1

ASSESSMENT CRITERIA			
SECTIONAL FRONT VIEW			
1	HOUSING	7	
2	PULLEY	8½	
3	WASHER	2	
4	NUT	4	
5	BOLT	15	
6	HATCHING	4½	
7	NON - HATCHING	5½	
8	CENTRE LINES	2	
9	TITLE, SCALE, SECTIONAL TITLE	1½	
PENALTIES (-)			
TOTAL		50	