



HILLCREST HIGH SCHOOL
PHYSICAL SCIENCE

GRADE 12
PAPER 2- CHEMISTRY 2



SEPTEMBER 2013
TIME: 3 HOURS

MARKS: 150

INSTRUCTIONS

1. Answer ALL the questions
2. This question paper consists of TWO sections
SECTION A (25)
SECTION B (125)
3. Answer both sections in the ANSWER BOOK
4. Non-programmable calculators may be used
5. Appropriate mathematical instruments may be used
6. Number the answers correctly according to the numbering system used in this question paper
7. Data sheets and periodic table are attached for your use
8. Give brief motivations, discussions, et cetera where required
9. Answers must be rounded off to **TWO** decimal places

SECTION A

QUESTION 1: ONE-WORD ITEMS

Give one word/term for each of the following descriptions. Write only the word/term next to the question number (1.1-1.5) in the ANSWER BOOK.

- 1.1 The stage reached in a chemical reaction when the rate of the forward reaction is equal to the rate of the reverse reaction.
- 1.2 The unstable intermediate compound formed during a chemical reaction.
- 1.3 The elimination of H_2O from an alcohol.
- 1.4 The only factor that affects the equilibrium constant.
- 1.5 The solid substance that transfers electrons to and from the ions, atoms and molecules of an electrolyte.

[5]

QUESTION 2: MULTIPLE CHOICE QUESTIONS

Four options are provided as possible answers to the following questions. Each question has only ONE correct answer. Write only the letter (A-D) next to the question number (2.1-2.10) in the ANSWER BOOK.

2.1 A homologous series is composed of substances with the same:

- A. Structural formula
- B. Molecular formula
- C. General formula
- D. Number of carbon atoms

2.2 In which one of the following equilibrium reactions is the yield of products favoured by increasing the pressure of the reaction mixture?

- A. $2\text{NO (g)} + \text{Cl}_2\text{ (g)} \rightleftharpoons 2\text{NOCl (g)}$
- B. $\text{CO (g)} + \text{H}_2\text{O (g)} \rightleftharpoons \text{CO}_2\text{ (g)} + \text{H}_2\text{ (g)}$
- C. $2\text{SO}_3\text{ (g)} \rightleftharpoons 2\text{SO}_2\text{ (g)} + \text{O}_2\text{ (g)}$
- D. $\text{PCl}_4\text{ (g)} \rightleftharpoons \text{PCl}_3\text{ (g)} + \text{Cl}_2\text{ (g)}$

2.3 When the enthalpy of a chemical reaction increases...

- A. ΔH is negative
- B. The reaction is endothermic
- C. The temperature in the reaction vessel will increase
- D. The reaction cannot take place spontaneously

2.4 One of the stages in the industrial preparation of iron ore from its ore is represented below:

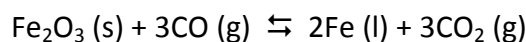

The following changes are made to the system:

- I. Fe_2O_3 is added
- II. CO_2 is removed
- III. CO is removed

Which one of the changes mentioned above will favour the **forward** reaction?

- A. I, II, and III
- B. I and II only
- C. II only
- D. III only

2.5 The gain of electrons by a substance in a chemical reaction is known as ...

- A. Oxidation
- B. Reduction
- C. Electrolysis
- D. Oxidation and reduction

2.6 The diagram below shows the change in potential energy for a hypothetical reaction, represented by the following equation:

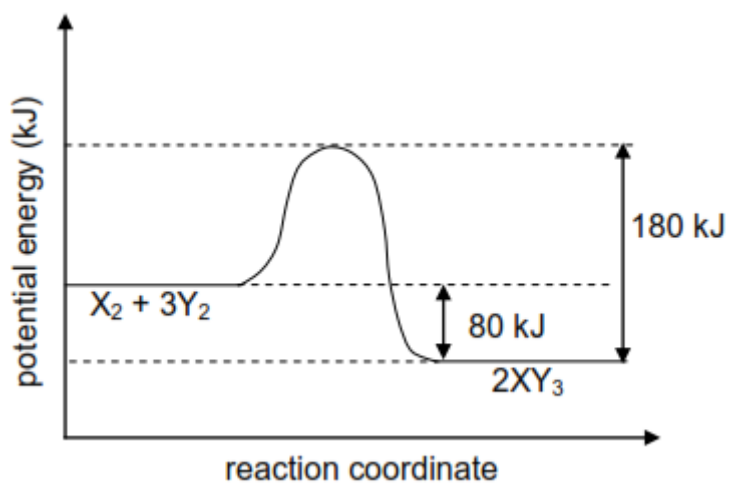
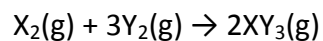

The activation energy for the forward reaction is ...

- A. -80 kJ
- B. 80 kJ
- C. 100 kJ
- D. 180 kJ

2.7 Which one of the compounds represented below is an example of an unsaturated hydrocarbon?

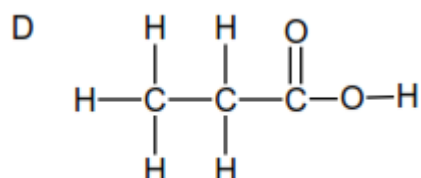
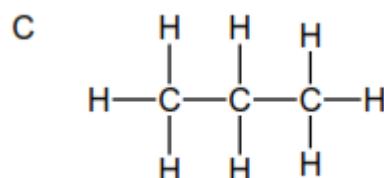
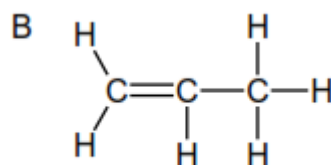
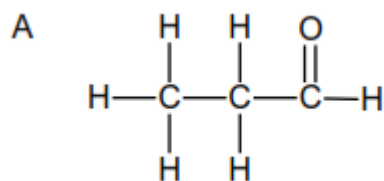

2.8 Consider the reaction represented below

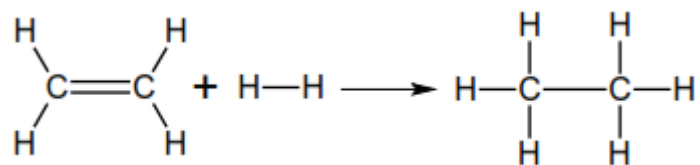

This reaction is an example of:

- A. Addition
- B. Oxidation
- C. Elimination
- D. Substitution

2.9 The Maxwell-Boltzmann energy distribution curves below show the number of particles as a function of their kinetic energy for a reaction at four different temperatures. The minimum kinetic energy needed for effective collisions to take place is represented by E.

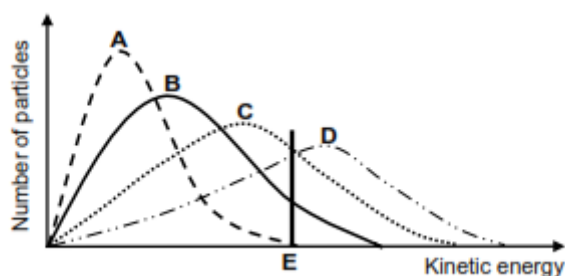

Which one of these curves represents the reaction with the highest rate?

- A. A
- B. B
- C. C
- D. D

2.10 Consider the two half reactions below that occur in a battery.

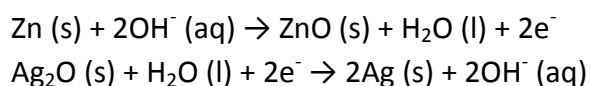

Which one of the following statements is correct?

- A. Ag (s) is reduced
- B. Zn (s) is the anode
- C. Ag₂O (s) is the negative electrode
- D. Electrons are transferred from Ag (s) to Zn (s)

[10 X 2=20]

SECTION B

INSTRUCTIONS AND INFORMATION

1. Leave one line between two sub questions, for example between QUESTION 3.1 and QUESTION 3.2.
2. Show the formula and substitution in ALL calculations.
3. Round off your numerical answers to **TWO** decimal places.

QUESTION 3

The letters **A** to **F** in the table below represent six organic compounds.

A	$\text{CH} \equiv \text{C} - \text{CH}_2 - \text{CH}_2 - \text{CH}_3$	B	$\text{CH}_3\text{CH}_2\text{CH}_2\underset{\text{OH}}{\text{CH}}\text{CH}_3$
C	$\text{CH}_2 = \underset{\text{CH}_3}{\overset{\text{CH}_3}{\text{C}}} - \text{CH}_2$	D	Pentanoic acid
E	$ \begin{array}{ccccccc} & \text{H} & & \text{H} & & \text{H} & & \text{O} \\ & & & & & & & \\ \text{H} & - \text{C} & - & \text{C} & - & \text{C} & - & \text{C} & - & \text{H} \\ & & & & & & & & & \\ & \text{H} & & \text{H} & - & \text{C} & - & \text{H} & & \text{H} \\ & & & & & & & & & \\ & & & & & \text{H} & & & & \end{array} $	F	$\text{CH}_3 - \text{CH}_2 - \text{O} - \overset{\text{O}}{\parallel}{\text{C}} - \text{CH}_2 - \text{CH}_3$

- 3.1 Write down the letter(s) that represent(s) each of the following:
(A compound may be used more than once.)
- 3.1.1 An alkyne (1)
 - 3.1.2 Two compounds that are structural isomers (2)
 - 3.1.3 A compound containing a carboxyl group (1)
 - 3.1.4 An aldehyde (1)
 - 3.1.5 An alcohol (1)
- 3.2 Write down the:
- 3.2.1 IUPAC name of compound **C** (2)
 - 3.2.2 Structural formula of compound **D** (2)

3.3 Compound **F** is prepared in the laboratory.

- 3.3.1 How can one quickly establish whether compound **F** is indeed being formed? (1)
- 3.3.2 Write down the IUPAC name of the alcohol needed to prepare compound **F**. (2)
- 3.3.3 Write down the IUPAC name of compound **F**. (2)
- [15]**

QUESTION 4

The table below shows the boiling points of four organic compounds, represented by the letters **A** to **D**, of comparable molecular mass.

	Compound	Molecular mass	Boiling point (°C)
A	Butane	58	0
B	Propanal	58	49
C	Propan-1-ol	60	97
D	Ethanoic acid	60	118

4.1 Compound **A** is used as a fuel in gas burners.

- 4.1.1 Is compound **A** in the GAS, LIQUID or SOLID phase at 25 °C? (1)
- 4.1.2 How will the boiling point of an ISOMER of compound **A** compare to that of compound **A**? Write down HIGHER THAN, LOWER THAN or EQUAL TO. Refer to MOLECULAR STRUCTURE, INTERMOLECULAR FORCES and the ENERGY needed to explain the answer. (4)
- 4.1.3 Using molecular formulae, write down the balanced equation for the combustion of compound **A** in excess oxygen. (3)
- 4.1.4 Compound **A** has a lower boiling point than compound **B**. Give reasons for this difference in boiling points by referring to the following: (2)
- Structural differences between the two compounds
 - Polarity

4.2 Consider the boiling points of compounds **C** and **D**.

- 4.2.1 Give a reason for this difference in boiling points by referring to the intermolecular forces present in EACH of these compounds. (2)
- 4.2.2 Which ONE of compound **C** or **D** has a higher vapour pressure? Refer to their boiling points to give a reason for the answer. (2)
- [14]**

QUESTION 5 (Start on a new page.)

In the flow diagram below **R**, **P** and **Q** represent different types of reactions.

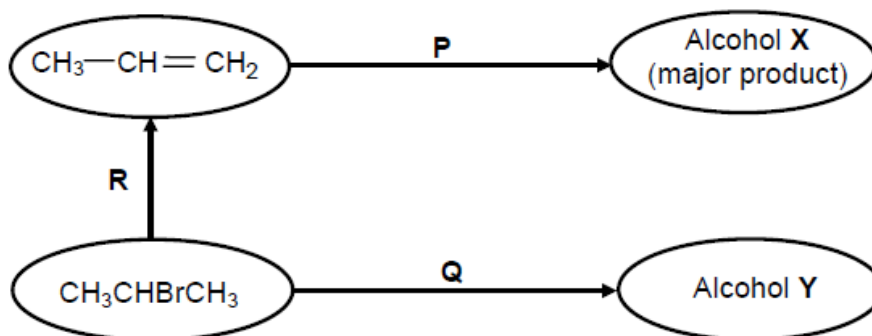

5.1 Name the type of reaction represented by:

5.1.1 **P** (1)

5.1.2 **Q** (1)

5.1.3 **R** (1)

5.2 Using structural formulae, write down a balanced equation for reaction **P**. (4)

5.3 Write down the IUPAC name of alcohol **Y**. (2)

5.4 Reaction **Q** takes place in the presence of a BASE. Write down TWO reaction conditions for this reaction. (2)
[11]

QUESTION 6

Some of the reactions in Butan-1-ol are represented in the following diagram below. **P**, **Q** and **R** represent the organic products formed.

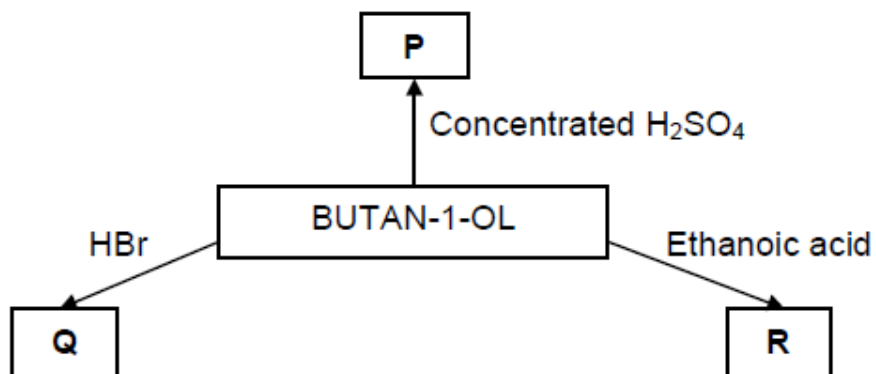

6.1 Is Butan-1-ol a primary, secondary or tertiary alcohol? (1)

6.2 Product **P** is formed when butan-1-ol is heated in the presence of concentrated sulphuric acid.

Write down the:

6.2.1 Name of the type of reaction that takes place (1)

6.2.2 Balanced equation for the reaction that takes place using structural formulae (5)

6.3 Product **R** is formed when butan-1-ol reacts with ethanoic acid in the presence of an acid catalyst.

Write down the:

6.3.1 Name the type of reaction that takes place (1)

6.3.2 Structural formula of the organic product formed (2)

6.4 When HBr reacts with butan-1-ol, compound **Q**, a haloalkane, is formed

Write down the:

6.4.1 Name of the type of reaction that takes place (1)

6.4.2 IUPAC name of the haloalkane formed (2)

[13]

QUESTION 7

The apparatus shown below is used to investigate the rate at which hydrogen gas is produced when a certain amount of zinc reacts with an excess of a dilute hydrochloric acid solution.

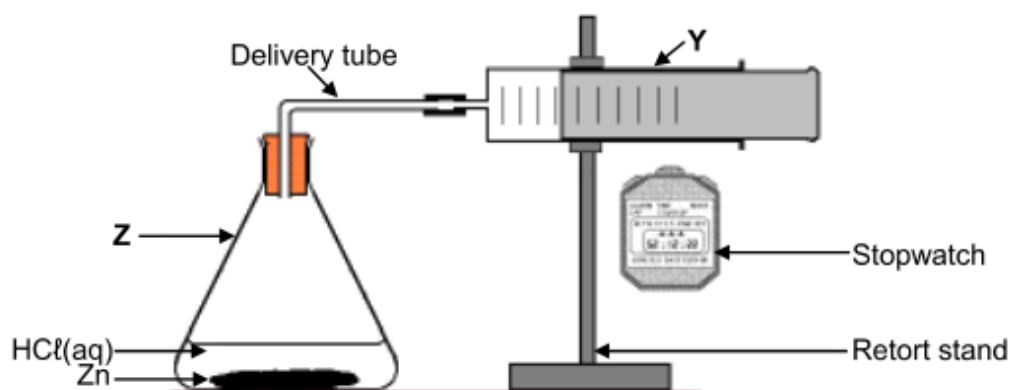

The reaction that takes place is represented by the following balanced equation:

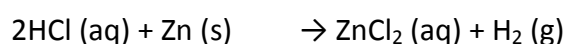

- 7.1 Write down the name of the flask labelled **Z** (1)
- 7.2 Write down one function of the item of apparatus labelled **Y** in this investigation (1)

Two experiments are conducted using the apparatus above. The conditions for each experiment are given in the table below.

	Experiment 1	Experiment 2
Zinc	powdered	powdered
Hydrochloric acid	0,1 mol·dm ⁻³	0,2 mol·dm ⁻³
Temperature	25 °C	25 °C

7.3 FROM THE TABLE ABOVE, WRITE DOWN:

- 7.3.1 The independent variable for this investigation (1)
- 7.3.2 ONE controlled variable (1)

The volume of hydrogen gas produced is measured in each experiment. The graphs below show the results obtained.

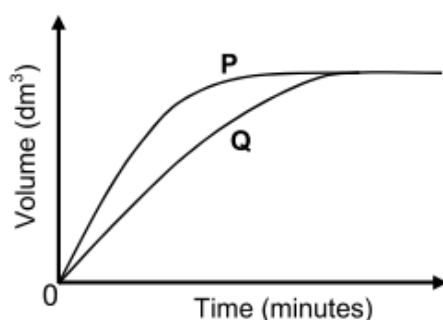

- 7.4 Which graph, P or Q represents experiment 2? Refer to the data given in the table, as well as the shape of the graph, to explain how you arrived at your answer. (3)
- 7.5 Give a reason why the rate of hydrogen production slows down towards the end in both experiments. (1)
- 7.6 Calculate the mass of zinc used to prepare 0.24 dm³ of hydrogen gas at room temperature. Assume that one mole of hydrogen gas has a volume of 24.04 dm³ at room temperature. (6)

[14]

QUESTION 8

8.1 The industrial preparation of hydrogen gas is represented below.

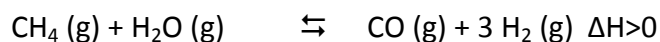

The reaction reaches equilibrium at 1000°C in a closed container

8.1.1 State Le Chatelier's principle (3)

8.1.2 How will an increase in pressure at 1000°C (by decreasing the volume) affect the yield of hydrogen gas? Write down ONLY INCREASES, DECREASES OR NO EFFECT. Explain your answer. (3)

8.1.3 Give **one** reasons why high temperatures are used for this reaction (1)

8.2 Study the reversible reaction represented by the balanced equation below.

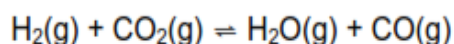

Initially x moles of $\text{H}_2(\text{g})$ is mixed with 0,3 moles of $\text{CO}_2(\text{g})$ in a sealed 10 dm^3 container. When equilibrium is reached at a certain temperature, it is found that 0,2 moles of $\text{H}_2\text{O}(\text{g})$ is present.

The equilibrium constant (K_c) for the reaction at this temperature is 4.

8.2.1 Calculate the initial number of moles of $\text{H}_2(\text{g})$, x , that was in the container (8)

8.2.2 The reaction is now carried out at a much higher temperature. It is found that K_c decreases at this higher temperature. Is this reaction exothermic or endothermic? Explain your answer. (3)

[18]

QUESTION 9

The reaction between hydrogen chloride and oxygen reaches equilibrium in a closed container according to the following balanced equation:

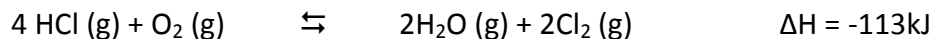

9.1 Is this reaction exothermic or endothermic? Give a reason for your answer. (2)

9.2 The graph below, not drawn to scale, show how the amounts of reactants present in the container change with time at a specific temperature. The volume of the container is 5dm^3 .

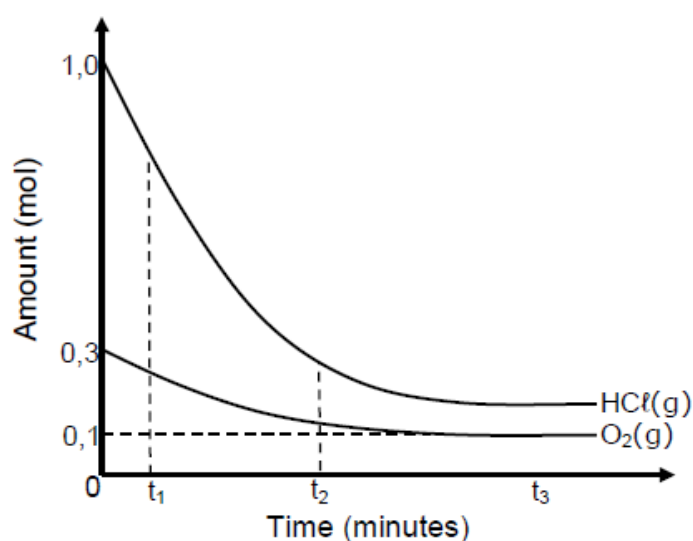

9.2.1 How does the rate of the forward reaction at time t_1 compare to that at time t_2 ? Write down GREATER THAN, SMALLER THAN or EQUAL to. Use the graphs to give a reason for your answer. (2)

9.2.2 How does the rate of the forward and the reverse reactions compare at time t_3 ? Write down only GREATER THAN, SMALLER THAN or EQUAL TO. (1)

9.3 The temperature is now increased. How will this change affect the value of the equilibrium constant? Write down INCREASE, DECREASE or REMAIN THE SAME. Explain the answer. (4)

9.4 How will each of the following changes affect the equilibrium concentration of $\text{Cl}_2 \text{(g)}$? Write down INCREASE, DECREASE or REMAIN THE SAME.

9.4.1 Water vapour is added (1)

9.4.2 A catalyst is added (1)

9.4.3 The volume of the container is increased (1)

[12]

QUESTION 10

The potential difference of a galvanic cell, measured experimentally by learners, is COMPARED with its potential difference calculated at standard conditions.

They set up the galvanic cell shown below.

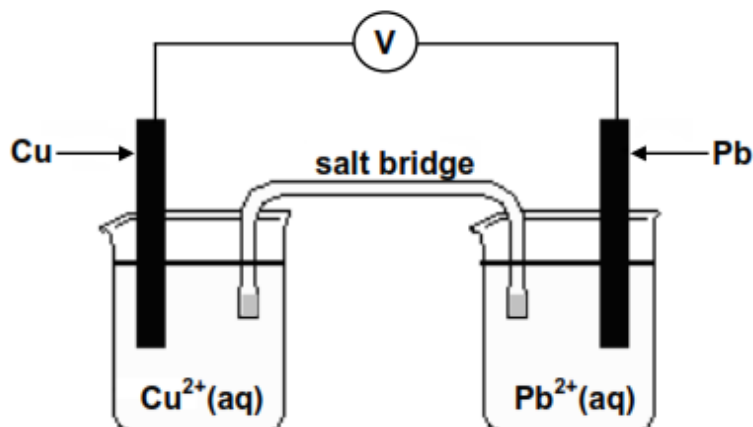

The voltmeter measures an initial reading of 0,3 V.

- 10.1 Write down the energy conversion that takes place in this cell (1)
- 10.2 State one function of the salt bridge (1)
- 10.3 Write down the half reaction that takes place at the anode (2)
- 10.4 In which direction do electrons flow in the external circuit when this cell delivers a current? Write down only 'from Cu to Pb ' or from 'Pb to Cu' (1)
- 10.5 Write down the balanced net (overall) cell reaction (3)
- 10.6 Is the cell reaction exothermic or endothermic? (1)
- 10.7 Use the tables of standard Reduction Potentials to calculate the initial potential difference (emf) of the above cell at STANDARD CONDITIONS (4)
- 10.8 From the results obtained the learners conclude that the measured potential difference differs from the calculated potential difference. Give two possible reasons for this difference in values. (4)

[17]

QUESTION 11

The simplified diagram below shows an electrolytic cell used at an electroplating company to coat iron spoons with silver.

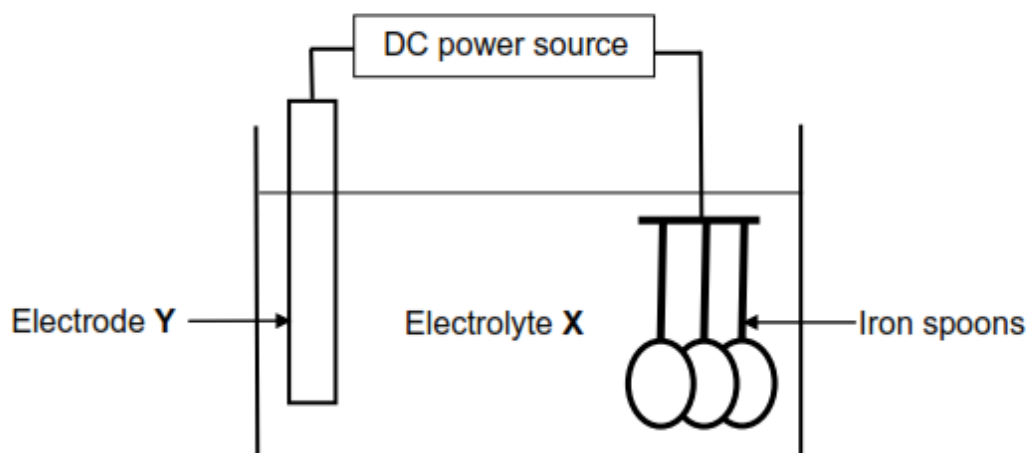

- 11.1 Write down the energy conversion that takes place in this cell (1)
- 11.2 Direct current is used in this process. Give a reason why alternating current is not used. (1)
- 11.3 Which type of reaction (OXIDATION or REDUCTION) takes place at the spoons? (1)
- 11.4 Write down the:
- 11.4.1 Equation for the half-reaction that takes place at electrode Y (2)
- 11.4.2 NAME or FORMULA of electrolyte X (1)
- 11.5 Give a reason why the concentration of electrolyte X remains constant during electroplating (2)
- 11.6 Apart from the income generated, write down one major reason why the company electroplates the spoons (1)
- 11.7 Write down the two major expenses for the company during the process (2)

[11]

TOTAL SECTION B: [125]

GRAND TOTAL: [150]