



HILLCREST HIGH SCHOOL
PHYSICAL SCIENCE
GRADE 12
PAPER 2 - CHEMISTRY



TRIALS 2019
EXAMINER: J. KNOX-WHITEHEAD

TIME: 3 HRS
TOTAL 150

Instructions

1. Answer ALL the questions.
2. This question paper consists of TWO sections:
3. SECTION A (20)
SECTION B (130)

Answer SECTIONS A and B in the ANSWER BOOK.
4. Non-programmable calculators may be used.
5. Appropriate mathematical instruments may be used.
6. Number the answers correctly according to the numbering system used in this question paper.
7. Data sheets and a periodic table are attached for your use.
8. Give brief motivations, discussions, et cetera where required.
9. Numbers must be rounded off to **two decimal** places

SECTION A**QUESTION 1: MULTIPLE CHOICE QUESTIONS**

Four options are given as possible answers to the following questions. Each question has only ONE correct answer. Write only the letter (A-D) next to the question number (1.1-1.10) in the ANSWER BOOK.

1.1 Which one of the following homologous series does not contain a CARBONYL group?

- A aldehydes
- B alcohols
- C carboxylic acids
- D esters

(2)

1.2 The structural formula of an organic compound is shown below:

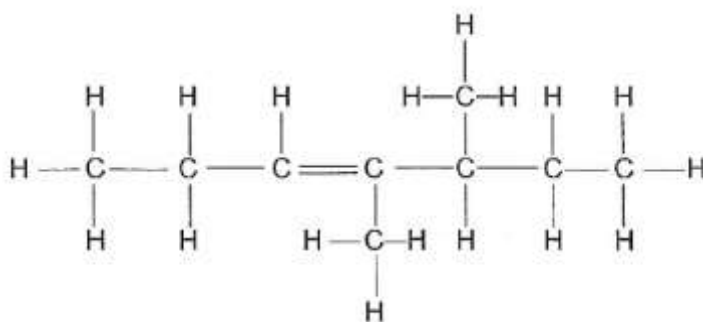

Which ONE of the following is the correct IUPAC name of this compound?

- A 4-methyl-5-ethylhept-3-ene
- B 4,5-dimethylhept-3-ene
- C 3,4-dimethylhept-4-ene
- D 3-methyl-4-ethylhept-4-ene

(2)

1.3 The energy distribution diagrams for particles in a fixed mass of gas at two different temperatures, T_1 and T_2 , are shown below:

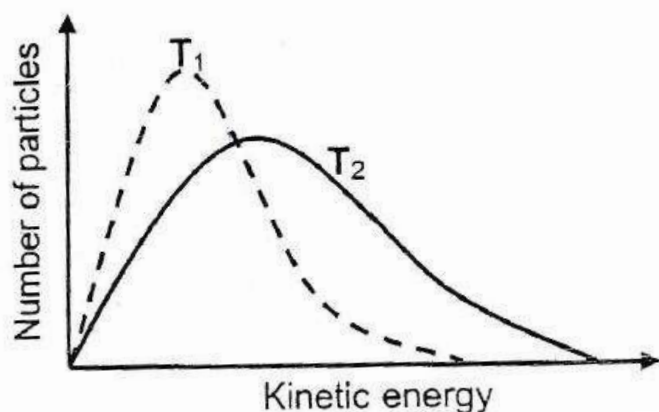

- 1.7 Which ONE of the following solutions can be stored in an aluminium container?
- A $\text{CuSO}_4(\text{aq})$
 - B $\text{ZnSO}_4(\text{aq})$
 - C $\text{NaCl}(\text{aq})$
 - D $\text{Pb}(\text{NO}_3)_2(\text{aq})$ (2)
- 1.8 $0,1 \text{ mol}\cdot\text{dm}^{-3}$ solutions of the four substances below are prepared. Which ONE will have the highest pH?
- A KOH
 - B NH_4OH
 - C NH_4NO_3
 - D KNO_3 (2)
- 1.9 MnO_4^- (aq) ions are reduced by hydrogen sulphide (H_2S) gas. The equation representing the oxidation half reaction is:
- A $\text{H}_2\text{S} \rightarrow 2\text{H}^+ + \text{S} + 2\text{e}^-$
 - B $2\text{H}^+ + \text{S} + 2\text{e}^- \rightarrow \text{H}_2\text{S}$
 - C $\text{Mn}^{2+} + 4\text{H}_2\text{O} \rightarrow \text{MnO}_4^- + 8\text{H}^+ + 5\text{e}^-$
 - D $\text{MnO}_4^- + 8\text{H}^+ + 5\text{e}^- \rightarrow \text{Mn}^{2+} + 4\text{H}_2\text{O}$ (2)
- 1.10 The process in industry whereby nitrogen gas is prepared is called:
- A Contact process
 - B Fractional distillation
 - C Ostwald process
 - D Haber process (2)

[20]

SECTION B**QUESTION 2**

Consider the following representation of organic molecules **A** to **E** listed in the table below:

A	$ \begin{array}{cccccccc} & & \text{H} & & \text{Br} & & \text{H} & & \text{H} \\ & & & & & & & & \\ \text{H} & - & \text{C} & - & \text{C} & - & \text{C} & - & \text{C} & - & \text{H} \\ & & & & & & & & \\ & & \text{H} & & \text{H} & & \text{H} & & \text{H} \end{array} $
B	3 – bromo – 2 – chloro – 2 – methylpentane
C	$\text{CH}_3\text{CH}(\text{CH}_3)\text{CH}_2\text{CH}(\text{CH}_3)\text{CH}_2\text{CH}_3$
D	$\text{CH}_3\text{CCCH}(\text{C}_2\text{H}_5)\text{CH}_2\text{CH}_3$
E	4 – methylpentan – 2 – one

2.1 Write down the letter that represents:

2.1.1 a saturated hydrocarbon.

(1)

2.1.2 a compound whose functional group is a carbonyl group bonded to two carbon atoms.

(1)

2.2 Write down the IUPAC name for the major product formed when compound **A** is dissolved in a concentrated solution of sodium hydroxide in pure ethanol and is strongly heated under reflux.

(2)

2.3 Write down the structural formula of compound **B**.

(2)

[6]

QUESTION 3

The table below shows the results obtained during an experiment to determine the boiling points of some alkanes and alcohols with comparable molecular masses.

	Compound	Relative molecular mass	Boiling point (°C)
A	CH ₃ CH ₃	30	-89
B	CH ₃ OH	32	65
C	CH ₃ CH ₂ CH ₃	44	-42
D	CH ₃ CH ₂ OH	46	78
E	CH ₃ CH ₂ CH ₂ CH ₃	58	0
F	CH ₃ CH ₂ CH ₂ OH	60	97
G	CH ₃ CH ₂ CH ₂ CH ₂ CH ₃	72	36
H	CH ₃ CH ₂ CH ₂ CH ₂ OH	74	117

- 3.1 Define the term *boiling point*. (2)
- 3.2 Consider the boiling points of the four alkanes (**A**, **C**, **E** and **G**) in the above table.
- 3.2.1 What is the phase of **G** at room temperature? (1)
- 3.2.2 Describe the tendency in boiling points of the alkanes from **A** to **G**. (1)
- 3.2.3 How will the boiling point of a chain isomer of **E** compare with the boiling point of compound **E**? (Choose from HIGHER THAN, LOWER THAN or THE SAME.) Explain your answer. (2)
- 3.3 The boiling point of alcohol **F** is much higher than that of alkane **E**. Explain this observation by referring to the type and strength of intermolecular forces in alkanes and alcohols as well as the energy involved. (3)
- 3.4 How will the vapour pressure of compound **H** compare with the vapour pressure of compound **B**? (Choose from HIGHER THAN, LOWER THAN or THE SAME.) (1)
- 3.5 Use structural formulae to draw a structural isomer of compound **H** which is also a tertiary alcohol. (2)
- 3.6 During a combustion reaction in a closed container of adjustable volume, 10 cm³ of compound **E** reacts in excess oxygen according to the following balanced equation:

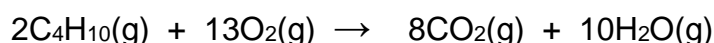

The initial volume of oxygen in the container is given as 70cm³.

(Assume that ALL the gases in the container are at the same temperature and pressure.)

Calculate the TOTAL volume of the gases that are present in the container by the end of the reaction. (5)

QUESTION 4

The flow diagram below shows how an alkene can be used to prepare other organic compounds. The letters **A** to **G** represent different organic reactions.

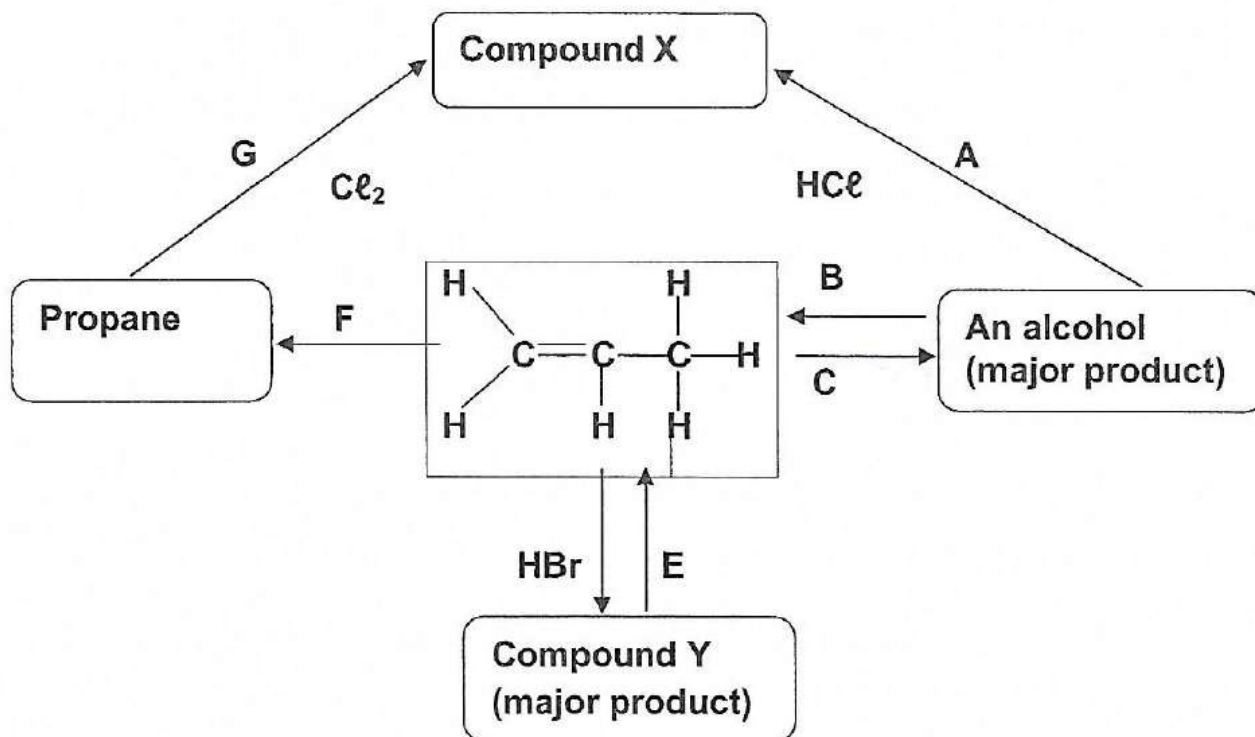

- 4.1 Write down the type of reaction represented by:
- 4.1.1 **F** (1)
 - 4.1.2 **G** (1)
 - 4.1.3 **B** (1)
- 4.2 Write down the IUPAC name of compound Y. (2)
- 4.3 For reaction **E**, write down:
- 4.3.1 The type of elimination reaction (1)
 - 4.3.2 TWO reaction conditions (2)
- 4.4 Write down the:
- 4.4.1 FORMULA of an inorganic reactant needed for reaction **C**. (1)
 - 4.4.2 Balanced chemical equation for reaction **A**, using STRUCTURAL FORMULAE. (4)
- 4.5 There are natural polymers and man-made polymers like plastics. Polythene is a plastic polymer that is widely used.
- 4.5.1 Describe *addition polymerisation*. (2)
 - 4.5.2 Write down ONE use of polythene (1)

QUESTION 5

- 5.1 The following equation represents a reaction used to prepare $\text{CO}_2(\text{g})$ in the school laboratory. Pieces of calcium carbonate are added to a $0,1 \text{ mol}\cdot\text{dm}^{-3}$ hydrochloric acid solution in a glass beaker.



- 5.1.1 Mention THREE ways to increase the rate of CO_2 production in the above reaction. (3)

- 5.1.2 Describe, in detail, TWO methods to measure the rate of this reaction. (4)

- 5.1.3 Explain why this reaction will NOT reach equilibrium in the beaker. (2)

- 5.2 In an investigation, different lengths of magnesium ribbon of the same width react with diluted hydrochloric acid of the same concentration. The rate at which hydrogen gas is produced in each reaction is measured and the data obtained is recorded in the table below:

Length of magnesium ribbon (cm)	1,0	2,0	3,0	4,0	5,0	6,0	7,0
Rate of production of H_2 $\left(\frac{\text{cm}^3}{\text{min}}\right)$ at 25°C	0,9	1,8	2,7	3,6	4,6	5,4	6,4

A graph of the results appears below:

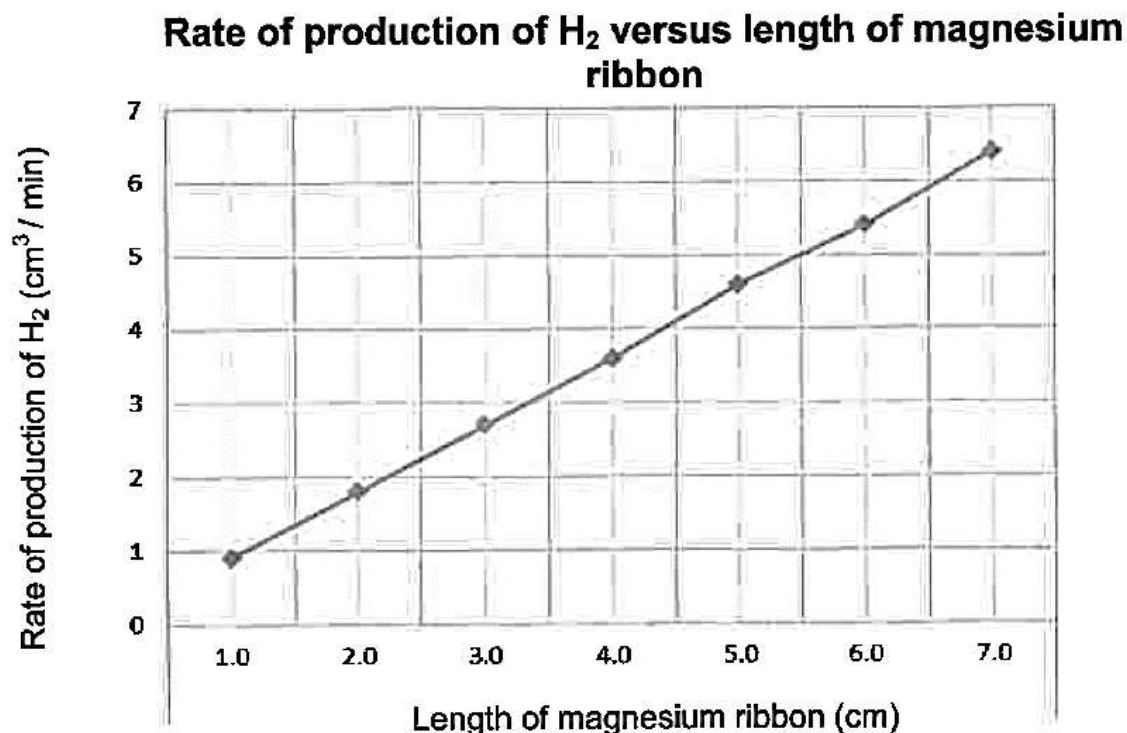

- 5.2.1 Use the graph to give the rate at which hydrogen gas is produced from a 5,5 cm length of magnesium ribbon. (1)
- 5.2.2 The experiment is repeated under the same conditions, except that the hydrochloric acid is heated to 60°C before the magnesium ribbon is added. How will the gradient of the new graph differ from that of the original gradient? Write only **STEEPER GRADIENT** or **LOWER GRADIENT**. (1)
- 5.2.3 Explain your answer to QUESTION 5.2.2 in terms of the collision theory. (2)
- 5.2.4 What conclusion can be made from the graph? (2)

[15]

QUESTION 6

- 6.1 State *Le Chatelier's principle*. (2)
- 6.2 Iodine reacts with excess hydrogen in a sealed container of constant volume. Hydrogen iodide is formed.

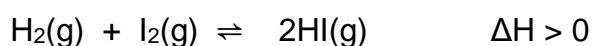

Samples of the initial reaction mixture and the equilibrium reaction mixture's molecular compositions are shown below.

An iodine atom is represented by \bigcirc and a hydrogen atom by \bullet .

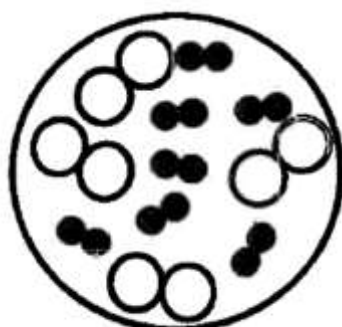

Initial reaction mixture

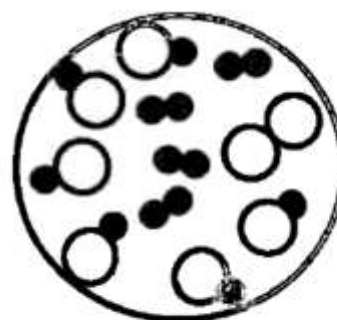

Reaction mixture at equilibrium

- 6.2.1 The temperature of the equilibrium mixture is decreased and a new equilibrium is established. Choose between **A** and **B** below to identify the new molecular composition of the reaction mixture. (1)

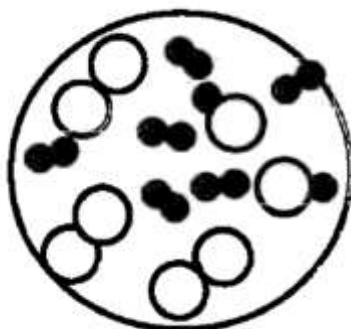
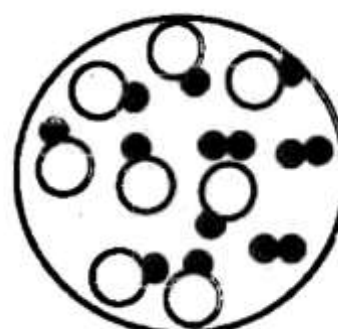
A**B**

- 6.2.2 Explain the answer to QUESTION 6.2.1. (3)

- 6.3 Consider the equilibrium established in an aqueous $0,10 \text{ mol.dm}^{-3}$ ethanoic acid solution at 25°C .



The pH of this solution is 2,87.

This pH corresponds to a $[\text{H}_3\text{O}^+] = 1,34 \times 10^{-3} \text{ mol.dm}^{-3}$

- 6.3.1 Calculate the equilibrium constant of an aqueous solution of ethanoic acid at 25°C . (3)
- 6.3.2 Concentrated sodium ethanoate (CH_3COONa) was dissolved in the ethanoic acid solution. How will the pH of the ethanoic acid solution change? Write only INCREASES, DECREASES or STAYS THE SAME. (1)
- 6.3.3 Explain the answer to QUESTION 6.3.2 (3)
- 6.4 Carbon dioxide reacts with carbon in a closed system to produce carbon monoxide, $\text{CO}(\text{g})$, according to the following balanced equation:

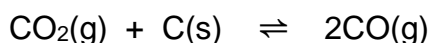

Initially an unknown amount of carbon dioxide is exposed to hot carbon at 800°C in a sealed 2 dm^3 container. The equilibrium constant, K_c , for the reaction at this temperature is 14.

At equilibrium it is found that 168,00 g carbon monoxide is present.

Calculate the initial amount (in moles) of $\text{CO}_2(\text{g})$ present. (9)

[22]

QUESTION 7

- 7.1 Sodium hydroxide is classified as a base according to the Arrhenius theory. Write down the chemical formula of the ion responsible for the basic properties of sodium hydroxide. (1)
- 7.2 Sulphuric acid reacts with water in two steps as represented by the equations below:
- Equation 1: $\text{H}_2\text{SO}_4(\text{aq}) + \text{H}_2\text{O}(\text{l}) \rightleftharpoons \text{H}_3\text{O}^+(\text{aq}) + \text{HSO}_4^-(\text{aq})$
- Equation 2: $\text{HSO}_4^-(\text{aq}) + \text{H}_2\text{O}(\text{l}) \rightleftharpoons \text{H}_3\text{O}^+(\text{aq}) + \text{SO}_4^{2-}(\text{aq})$
- 7.2.1 A learner suggests that $\text{HSO}_4^-(\text{aq})$ is an ampholyte. Give a reason to support the learner's suggestion. (2)
- 7.2.2 Write down the NAME of the conjugate base of the hydrogen sulphate ion. (1)

- 7.3 During an experiment $0,50 \text{ dm}^3$ of a $0,10 \text{ mol}\cdot\text{dm}^{-3}$ HCl solution is added to $0,80 \text{ dm}^3$ of a $\text{Ca}(\text{OH})_2$ solution of concentration $0,25 \text{ mol}\cdot\text{dm}^{-3}$. The balanced equation for the reaction is:

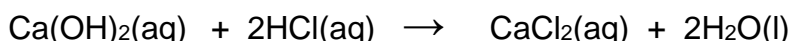

7.3.1 Define *end point* of a titration. (1)

7.3.2 Calculate the concentration of the hydroxide ions in the solution on completion of the reaction (8)

7.3.3 Calculate the pH of the solution on completion of the reaction. (4)

[17]

QUESTION 8

A galvanic cell is set up based on the reaction represented by the equation below. The reaction takes place under standard conditions.

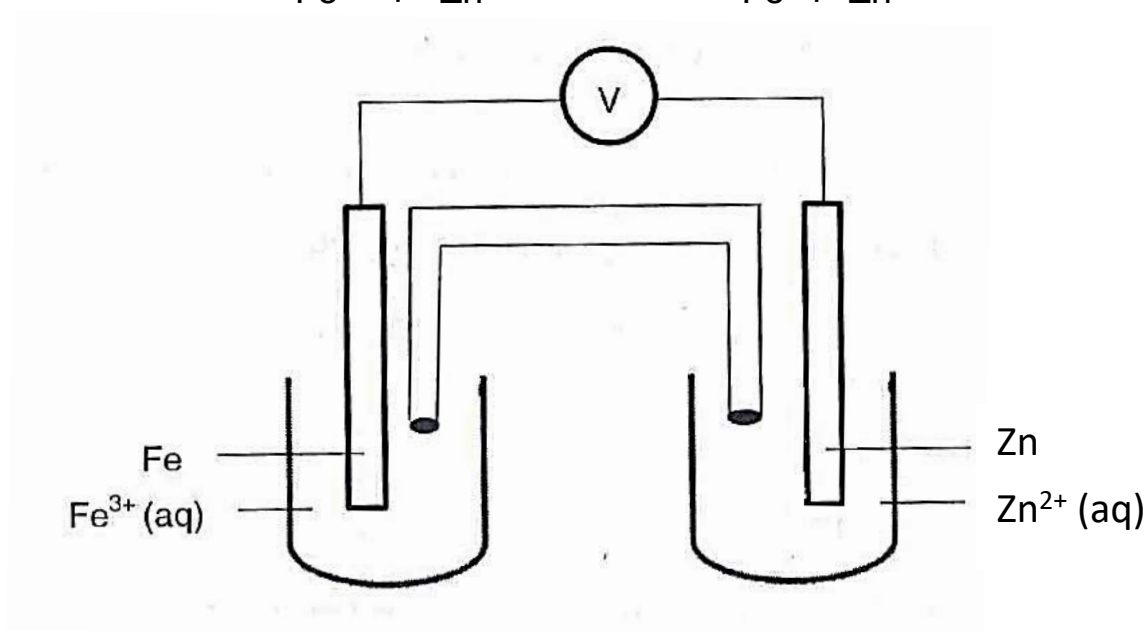
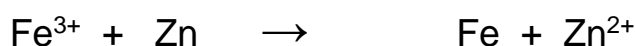

8.1 Define the term *oxidation* in terms of oxidation number. (2)

8.2 State TWO functions of the salt bridge. (2)

8.3 Write down the:

8.3.1 Half-reaction that takes place at the cathode. (2)

8.3.2 Cell notation for this cell. (3)

8.4 Calculate the mass gained at the cathode if the mass loss at the anode was 72 g. (4)

8.5 Write down the value of the reading on the voltmeter when the cell reaction reaches equilibrium. (1)

[14]

QUESTION 9

High purity silver is obtained by electrolysis using a thin, pure silver cathode and an acidified solution of silver sulphate.

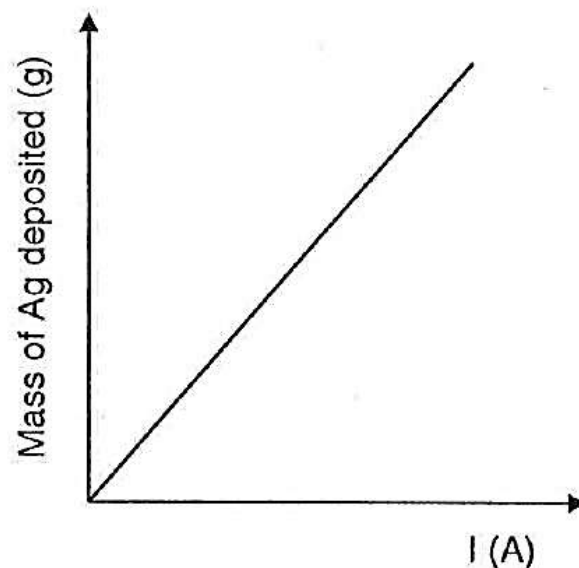
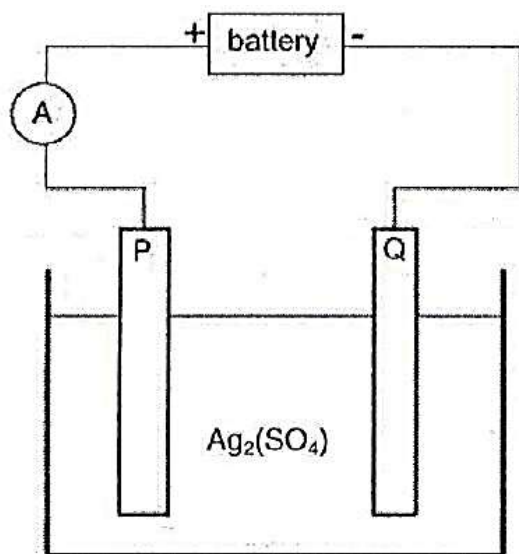

- 9.1 Define the term *electrolysis*. (2)
- 9.2 Write down the:
- 9.2.1 Half reaction that takes place at the anode. (2)
- 9.2.2 Net cell reaction that takes place in the cell. (2)
- 9.3 State the relationship between CURRENT and the MASS DEPOSITED depicted by the graph. (1)
- 9.4 When a constant current flows for 60 min, 17 g of pure silver is deposited at one of the electrodes.
- 9.4.1 At which electrode, **P** or **Q**, will the silver be deposited? (1)
- 9.4.2 Would the mass loss at the other electrode be LARGER THAN, SMALLER THAN or EQUAL TO 17 g? (1)
- 9.4.3 Calculate the number of electrons transferred. (4)

[13]

QUESTION 10

10.1 The flow diagram below represents the processes used to manufacture fertiliser **A**. Both the Haber and the Ostwald processes are part of the total process.

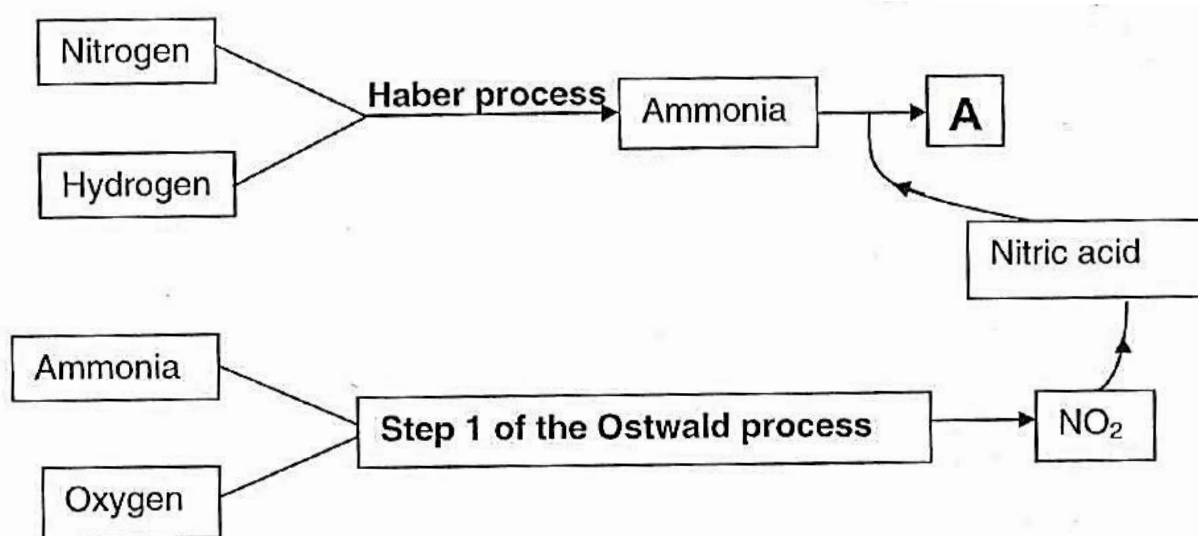

10.1.1 Write down the name of a suitable catalyst used in the Haber process. (1)

10.1.2 Write down the FORMULA of the compound represented by **A**. (1)

10.1.3 Write down a balanced chemical equation for **STEP 1 of the Ostwald process**. (3)

10.2 You want to start a vegetable garden in your community. You obtain the following bags of fertilisers as described below:

X: 4:6:9 (43)

Y: 15:3:3 (51)

10.2.1 From fertilisers **X** and **Y**, choose a fertiliser most suitable for growth of tomatoes. (1)

10.2.2 Give a reason for the answer to QUESTION 10.2.1. (1)

10.2.3 Calculate the mass of potassium in a 20 kg bag of fertiliser **Y**. (3)

[10]

TOTAL 150

CAPS
 INFORMATION FOR PHYSICAL SCIENCES GR 12
 PAPER 2 (CHEMISTRY)

TABLE 1: PHYSICAL CONSTANTS

NAME/NAAM	SYMBOL/SIMBOOL	VALUE/WAARDE
Standard pressure <i>Standaarddruk</i>	p^θ	$1,013 \times 10^5 \text{ Pa}$
Molar gas volume at STP <i>Molêre gasvolume by STD</i>	V_m	$22,4 \text{ dm}^3 \cdot \text{mol}^{-1}$
Standard temperature <i>Standaardtemperatuur</i>	T^θ	273 K
Charge on electron <i>Lading op elektron</i>	e	$-1,6 \times 10^{-19} \text{ C}$
Avogadro's constant <i>Avogadro-konstante</i>	N_A	$6,02 \times 10^{23} \text{ mol}^{-1}$

TABLE 2: FORMULAE

$n = \frac{m}{M}$	$n = \frac{N}{N_A}$
$c = \frac{n}{V}$ OR $c = \frac{m}{MV}$	$n = \frac{V}{V_m}$
$\frac{c_a V_a}{c_b V_b} = \frac{n_a}{n_b}$	$\text{pH} = -\log[\text{H}_3\text{O}^+]$
$K_w = [\text{H}_3\text{O}^+][\text{OH}^-] = 1 \times 10^{-14}$ at 298 K	
$E_{\text{cell}}^\theta = E_{\text{cathode}}^\theta - E_{\text{anode}}^\theta$	
$E_{\text{cell}}^\theta = E_{\text{reduction}}^\theta - E_{\text{oxidation}}^\theta$	
$E_{\text{cell}}^\theta = E_{\text{oxidising agent}}^\theta - E_{\text{reducing agent}}^\theta$	

CAPS

TABLE 4A: STANDARD REDUCTION POTENTIALS

Half-reactions		E° (V)
$F_2(g) + 2e^-$	$\rightleftharpoons 2F^-$	+ 2,87
$Co^{3+} + e^-$	$\rightleftharpoons Co^{2+}$	+ 1,81
$H_2O_2 + 2H^+ + 2e^-$	$\rightleftharpoons 2H_2O$	+1,77
$MnO_4^- + 8H^+ + 5e^-$	$\rightleftharpoons Mn^{2+} + 4H_2O$	+ 1,51
$Cl_2(g) + 2e^-$	$\rightleftharpoons 2Cl^-$	+ 1,36
$Cr_2O_7^{2-} + 14H^+ + 6e^-$	$\rightleftharpoons 2Cr^{3+} + 7H_2O$	+ 1,33
$O_2(g) + 4H^+ + 4e^-$	$\rightleftharpoons 2H_2O$	+ 1,23
$MnO_2 + 4H^+ + 2e^-$	$\rightleftharpoons Mn^{2+} + 2H_2O$	+ 1,23
$Pt^{2+} + 2e^-$	$\rightleftharpoons Pt$	+ 1,20
$Br_2(l) + 2e^-$	$\rightleftharpoons 2Br^-$	+ 1,07
$NO_3^- + 4H^+ + 3e^-$	$\rightleftharpoons NO(g) + 2H_2O$	+ 0,96
$Hg^{2+} + 2e^-$	$\rightleftharpoons Hg(l)$	+ 0,85
$Ag^+ + e^-$	$\rightleftharpoons Ag$	+ 0,80
$NO_3^- + 2H^+ + e^-$	$\rightleftharpoons NO_2(g) + H_2O$	+ 0,80
$Fe^{3+} + e^-$	$\rightleftharpoons Fe^{2+}$	+ 0,77
$O_2(g) + 2H^+ + 2e^-$	$\rightleftharpoons H_2O_2$	+ 0,68
$I_2 + 2e^-$	$\rightleftharpoons 2I^-$	+ 0,54
$Cu^+ + e^-$	$\rightleftharpoons Cu$	+ 0,52
$SO_2 + 4H^+ + 4e^-$	$\rightleftharpoons S + 2H_2O$	+ 0,45
$2H_2O + O_2 + 4e^-$	$\rightleftharpoons 4OH^-$	+ 0,40
$Cu^{2+} + 2e^-$	$\rightleftharpoons Cu$	+ 0,34
$SO_4^{2-} + 4H^+ + 2e^-$	$\rightleftharpoons SO_2(g) + 2H_2O$	+ 0,17
$Cu^{2+} + e^-$	$\rightleftharpoons Cu^+$	+ 0,16
$Sn^{4+} + 2e^-$	$\rightleftharpoons Sn^{2+}$	+ 0,15
$S + 2H^+ + 2e^-$	$\rightleftharpoons H_2S(g)$	+ 0,14
$2H^+ + 2e^-$	$\rightleftharpoons H_2(g)$	0,00
$Fe^{3+} + 3e^-$	$\rightleftharpoons Fe$	- 0,06
$Pb^{2+} + 2e^-$	$\rightleftharpoons Pb$	- 0,13
$Sn^{2+} + 2e^-$	$\rightleftharpoons Sn$	- 0,14
$Ni^{2+} + 2e^-$	$\rightleftharpoons Ni$	- 0,27
$Co^{2+} + 2e^-$	$\rightleftharpoons Co$	- 0,28
$Cd^{2+} + 2e^-$	$\rightleftharpoons Cd$	- 0,40
$Cr^{3+} + e^-$	$\rightleftharpoons Cr^{2+}$	- 0,41
$Fe^{2+} + 2e^-$	$\rightleftharpoons Fe$	- 0,44
$Cr^{3+} + 3e^-$	$\rightleftharpoons Cr$	- 0,74
$Zn^{2+} + 2e^-$	$\rightleftharpoons Zn$	- 0,76
$2H_2O + 2e^-$	$\rightleftharpoons H_2(g) + 2OH^-$	- 0,83
$Cr^{2+} + 2e^-$	$\rightleftharpoons Cr$	- 0,91
$Mn^{2+} + 2e^-$	$\rightleftharpoons Mn$	- 1,18
$Al^{3+} + 3e^-$	$\rightleftharpoons Al$	- 1,66
$Mg^{2+} + 2e^-$	$\rightleftharpoons Mg$	- 2,36
$Na^+ + e^-$	$\rightleftharpoons Na$	- 2,71
$Ca^{2+} + 2e^-$	$\rightleftharpoons Ca$	- 2,87
$Sr^{2+} + 2e^-$	$\rightleftharpoons Sr$	- 2,89
$Ba^{2+} + 2e^-$	$\rightleftharpoons Ba$	- 2,90
$Cs^+ + e^-$	$\rightleftharpoons Cs$	- 2,92
$K^+ + e^-$	$\rightleftharpoons K$	- 2,93
$Li^+ + e^-$	$\rightleftharpoons Li$	- 3,05

Increasing oxidising ability

Increasing reducing ability

TABLE 4B: STANDARD REDUCTION POTENTIALS

Half-reactions		E° (V)
$\text{Li}^+ + \text{e}^-$	\rightleftharpoons Li	-3,05
$\text{K}^+ + \text{e}^-$	\rightleftharpoons K	-2,93
$\text{Cs}^+ + \text{e}^-$	\rightleftharpoons Cs	-2,92
$\text{Ba}^{2+} + 2\text{e}^-$	\rightleftharpoons Ba	-2,90
$\text{Sr}^{2+} + 2\text{e}^-$	\rightleftharpoons Sr	-2,89
$\text{Ca}^{2+} + 2\text{e}^-$	\rightleftharpoons Ca	-2,87
$\text{Na}^+ + \text{e}^-$	\rightleftharpoons Na	-2,71
$\text{Mg}^{2+} + 2\text{e}^-$	\rightleftharpoons Mg	-2,36
$\text{Al}^{3+} + 3\text{e}^-$	\rightleftharpoons Al	-1,66
$\text{Mn}^{2+} + 2\text{e}^-$	\rightleftharpoons Mn	-1,18
$\text{Cr}^{2+} + 2\text{e}^-$	\rightleftharpoons Cr	-0,91
$2\text{H}_2\text{O} + 2\text{e}^-$	\rightleftharpoons $\text{H}_2(\text{g}) + 2\text{OH}^-$	-0,83
$\text{Zn}^{2+} + 2\text{e}^-$	\rightleftharpoons Zn	-0,76
$\text{Cr}^{3+} + 3\text{e}^-$	\rightleftharpoons Cr	-0,74
$\text{Fe}^{2+} + 2\text{e}^-$	\rightleftharpoons Fe	-0,44
$\text{Cr}^{3+} + \text{e}^-$	\rightleftharpoons Cr^{2+}	-0,41
$\text{Cd}^{2+} + 2\text{e}^-$	\rightleftharpoons Cd	-0,40
$\text{Co}^{2+} + 2\text{e}^-$	\rightleftharpoons Co	-0,28
$\text{Ni}^{2+} + 2\text{e}^-$	\rightleftharpoons Ni	-0,27
$\text{Sn}^{2+} + 2\text{e}^-$	\rightleftharpoons Sn	-0,14
$\text{Pb}^{2+} + 2\text{e}^-$	\rightleftharpoons Pb	-0,13
$\text{Fe}^{3+} + 3\text{e}^-$	\rightleftharpoons Fe	-0,06
$2\text{H}^+ + 2\text{e}^-$	\rightleftharpoons $\text{H}_2(\text{g})$	0,00
$\text{S} + 2\text{H}^+ + 2\text{e}^-$	\rightleftharpoons $\text{H}_2\text{S}(\text{g})$	+0,14
$\text{Sn}^{4+} + 2\text{e}^-$	\rightleftharpoons Sn^{2+}	+0,15
$\text{Cu}^{2+} + \text{e}^-$	\rightleftharpoons Cu^+	+0,16
$\text{SO}_4^{2-} + 4\text{H}^+ + 2\text{e}^-$	\rightleftharpoons $\text{SO}_2(\text{g}) + 2\text{H}_2\text{O}$	+0,17
$\text{Cu}^{2+} + 2\text{e}^-$	\rightleftharpoons Cu	+0,34
$2\text{H}_2\text{O} + \text{O}_2 + 4\text{e}^-$	\rightleftharpoons 4OH^-	+0,40
$\text{SO}_2 + 4\text{H}^+ + 4\text{e}^-$	\rightleftharpoons $\text{S} + 2\text{H}_2\text{O}$	+0,45
$\text{Cu}^+ + \text{e}^-$	\rightleftharpoons Cu	+0,52
$\text{I}_2 + 2\text{e}^-$	\rightleftharpoons 2I^-	+0,54
$\text{O}_2(\text{g}) + 2\text{H}^+ + 2\text{e}^-$	\rightleftharpoons H_2O_2	+0,68
$\text{Fe}^{3+} + \text{e}^-$	\rightleftharpoons Fe^{2+}	+0,77
$\text{NO}_3^- + 2\text{H}^+ + \text{e}^-$	\rightleftharpoons $\text{NO}_2(\text{g}) + \text{H}_2\text{O}$	+0,80
$\text{Ag}^+ + \text{e}^-$	\rightleftharpoons Ag	+0,80
$\text{Hg}^{2+} + 2\text{e}^-$	\rightleftharpoons $\text{Hg}(\text{l})$	+0,85
$\text{NO}_3^- + 4\text{H}^+ + 3\text{e}^-$	\rightleftharpoons $\text{NO}(\text{g}) + 2\text{H}_2\text{O}$	+0,96
$\text{Br}_2(\text{l}) + 2\text{e}^-$	\rightleftharpoons 2Br^-	+1,07
$\text{Pt}^{2+} + 2\text{e}^-$	\rightleftharpoons Pt	+1,20
$\text{MnO}_2 + 4\text{H}^+ + 2\text{e}^-$	\rightleftharpoons $\text{Mn}^{2+} + 2\text{H}_2\text{O}$	+1,23
$\text{O}_2(\text{g}) + 4\text{H}^+ + 4\text{e}^-$	\rightleftharpoons $2\text{H}_2\text{O}$	+1,23
$\text{Cr}_2\text{O}_7^{2-} + 14\text{H}^+ + 6\text{e}^-$	\rightleftharpoons $2\text{Cr}^{3+} + 7\text{H}_2\text{O}$	+1,33
$\text{Cl}_2(\text{g}) + 2\text{e}^-$	\rightleftharpoons 2Cl^-	+1,36
$\text{MnO}_4^- + 8\text{H}^+ + 5\text{e}^-$	\rightleftharpoons $\text{Mn}^{2+} + 4\text{H}_2\text{O}$	+1,51
$\text{H}_2\text{O}_2 + 2\text{H}^+ + 2\text{e}^-$	\rightleftharpoons $2\text{H}_2\text{O}$	+1,77
$\text{Co}^{3+} + \text{e}^-$	\rightleftharpoons Co^{2+}	+1,81
$\text{F}_2(\text{g}) + 2\text{e}^-$	\rightleftharpoons 2F^-	+2,87

Increasing oxidising ability

Increasing reducing ability